

# Instruction Manual

---

Installation and Operating Instructions



**Speed Flow Compact**

**SLD - Single Line Diverter 24V**

**DLD - Double Line Diverter 24V**

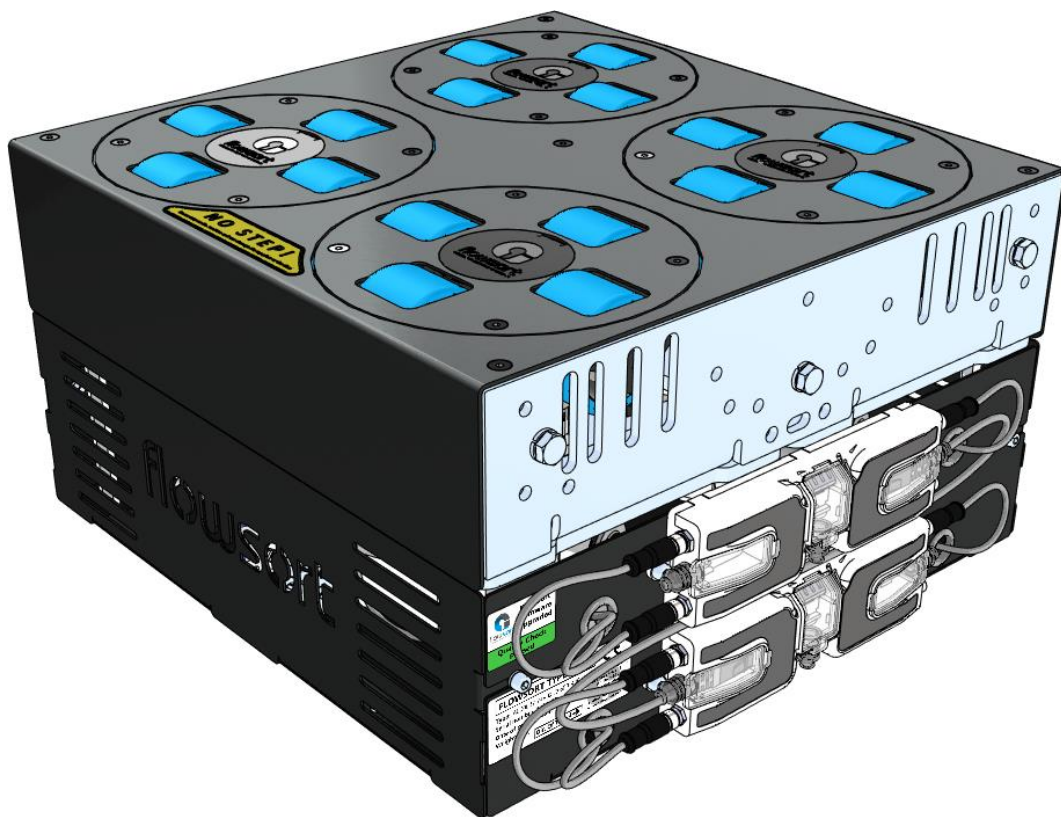



**Manufacturer's address:**

**Flowsort Kft.**

Gyár u. 2

2040 Budaörs

Hungary

**T:** +36 23 880-977

**W:** [www.flow-sort.com](http://www.flow-sort.com)

**E:** [info.hu@flow-sort.com](mailto:info.hu@flow-sort.com)

**Version: 1.0 – REV1.0**

**09-04-2024**

The copyright of these installation and operating instructions remains with Flowsort BV. The installation and operating instructions contain technical regulations and drawings which may not be reproduced partially or in full, transmitted by any means, utilized without permission for competitive purposes or disclosed to third parties.

**TABLE OF CONTENTS**

**TABLE OF CONTENTS ..... - 3 -**

**SAFETY PRECAUTIONS ..... - 5 -**

    1.1 general warning ..... - 5 -

        1.1.1 installation ..... - 5 -

        1.1.2 operations ..... - 5 -

    1.2 general caution ..... - 6 -

        1.2.1 installation ..... - 6 -

        1.2.2 maintenance ..... - 7 -

    1.3 symbols ..... - 7 -

    1.4 risk analysis ..... - 8 -

**PRODUCT INFORMATION ..... - 9 -**

    2.1 technical data sheet ..... - 9 -

    2.2 product description ..... - 10 -

    2.3 options ..... - 10 -

**PRECAUTIONS BEFORE USE ..... - 11 -**

    3.1 explanation part names ..... - 11 -

    3.2 additional documentation for application ..... - 11 -

    3.3 staff training ..... - 11 -

    3.4 safe operation ..... - 11 -

**INSTALLATION ..... - 12 -**

    4.1 general rules ..... - 12 -

    4.2 installation ..... - 12 -

    4.3 lifting and transportation of the diverters ..... - 13 -

    4.4 assembly/disassembly sld/dld diverter vs framework ..... - 14 -

    4.5 wiring and grounding of the sld/dld diverter ..... - 15 -

**OPERATION ..... - 16 -**

    5.1 first checks before operating ..... - 16 -

    5.2 during operation ..... - 16 -

    5.3 in case of an accident ..... - 16 -

    5.4 set-up diverting angle ..... - 16 -

**MAINTENANCE ..... - 17 -**

    6.1 maintenance intervals ..... - 17 -

    6.2 general maintenance information ..... - 17 -

    6.3 cleaning the blue wheels ..... - 17 -

    6.4 spare parts ..... - 17 -

    6.5 inspection sld/dld diverter ..... - 18 -

    6.6 removal and replacement of parts ..... - 20 -

        6.6.1 cover removal/replacement ..... - 20 -

        6.6.2 wheel geared drive removal/replacement ..... - 21 -

        6.6.3 wheel drive assembly removal/replacement ..... - 22 -

        6.6.4 pulley drive assembly removal/replacement ..... - 23 -

        6.6.5 swivel geared drive removal/replacement ..... - 24 -

        6.6.6 bevel gear assembly removal/replacement ..... - 25 -

6.6.7	setting the bevel gear gap for motors.....	- 26 -
6.6.8	control card removal/replacement.....	- 29 -
6.6.9	bevel gear removal/replacement.....	- 30 -
6.6.10	inductive sensor removal/replacement.....	- 31 -
6.6.11	tensioner removal/replacement.....	- 32 -
6.6.12	timing belt removal/replacement.....	- 33 -
6.6.13	SLD/DLD wheel replacement in wheel drive assembly.....	- 34 -
6.7	tensioning the belts.....	- 35 -
6.7.1	tensioning tool.....	- 35 -
6.7.2	tensioning the htd timing belts.....	- 35 -
6.7.3	tensioning the htd timing belt with the digital force gauge.....	- 36 -
6.7.4	tensioning the poly-v belts.....	- 37 -
6.7.5	tensioning the poly-v belt with digital force gauge.....	- 38 -
6.7.6	maintenance and re-tensioning.....	- 39 -
<b>TROUBLESHOOTING.....</b>		<b>- 40 -</b>
7.1	troubleshooting.....	- 40 -
<b>SPARE PARTS.....</b>		<b>- 41 -</b>
8.7	spare parts.....	- 41 -
<b>DECLARATION OF INCORPORATION.....</b>		<b>- 44 -</b>
<b>DECLARATION OF CONFORMITY.....</b>		<b>- 45 -</b>

## SAFETY PRECAUTIONS

### 1.1 GENERAL WARNING



**Warning: Indicates an imminently hazardous situation which, if not avoided, will result in death or serious injury.**

Do not use the product in an explosive atmosphere, flammable gas atmosphere, corrosive atmosphere, a place exposed to water splashes, or a place close to combustibles. It may cause an electric shock, injury and/or fire.

All work (e.g., installation, connection, operation, maintenance and failure diagnostics) must be done by a qualified and well trained person. Failure to do so may cause a fire, electric shock and/or injury.

Machine movements are very dangerous. Do not conduct operations as moving, installation, connection and maintenance while the power is on. Be sure to conduct such operations after turning off the power in order to prevent injury and/or accidents.

#### 1.1.1 INSTALLATION

Never touch the power supply when installing PGD/control card of the SLD/DLD diverter. It may cause an electric shock and/or injury.

Please check the specifications of the power supply, the voltage 24V ( $\pm 5\%$ ), before wiring. Failure to do so may cause a fire, electric shock, injury and/or breakage.

The diverter shall be incorporated into an emergency stop circuit arranged by the system integrator.

Please make sure that the control circuit has to meet standard EN-IEC 60204-1 and that the emergency stop system must be provided according EN-ISO13850.

#### 1.1.2 OPERATIONS

Do not touch the internal structure during operation to prevent entanglement and/or clamping accidents. Be sure to add instructions such as start/stop, after switching on the power. It may cause an injury and/or accident due to unexpected start-up.

If control card protection function worked, remove the cause prior to release the function. Otherwise, malfunction may occur again and it could result in an accident, injury and/or breakage.

If abnormal noises are being given out from the SLD/DLD diverter, turn off the power switch and cut the power supply immediately to avoid unpredictable accidents. Immediately rectify any defects or damage which occurs.

Do not use the unit in any way beyond its specifications. It may cause an injury and/or breakage.

Safety and danger notices must be fully legible.

## 1.2 GENERAL CAUTION



**Caution: Indicates a potentially hazardous situation which, if not avoided, may result in minor or moderate injury and could cause property damage.**

Never store or leave the SLD/DLD diverter outdoors.

Do not climb and/or overload on the product. It may cause an accident and/or breakage.

Do not exceed the maximum load capacity or insert objects into gaps. It may cause an accident and/or breakage. The SLD/DLD diverter must be in a good/safe condition.

Never modify the main unit of the SLD/DLD diverter and control card. It may cause an accident, injury and/or breakage.

Make sure that no liquids can get onto the SLD/DLD diverter. It may cause an electric shock, injury and/or breakage. The SLD/DLD diverter is not provided with dust- and/or waterproof function.

Prevent high impact, such as dropping or striking the SLD/DLD diverter. It may cause an accident and/ or breakage.

Do not touch the product immediately after operation. It can get very hot and there is a danger that you may get burned and/or injured.

Wear gloves as many metallic parts are used for the SLD/DLD diverter. Failure to do so may cause an injury.

No loose clothes, jewellery or loose hair allowed when working with this machinery.

Do not install the SLD/DLD diverter in a place with high vibration.

Take measures against gravity fall of the unit loads when the unit is installed at elevated position, i.e. side rails/ guards.

### 1.2.1 INSTALLATION

Always install the product horizontally and make sure it is well mounted in the framework.

Do not pull, bend or twist the electric cable with unnecessary force. There is a danger of fire or electric shock due to breakage.

The DC power supply must be earthed. It may cause an electric shock in case of a breakdown or electrical leakage.

Keep sufficient working space around the SLD/DLD diverter for maintenance.

Wear protective shoes during installation (gravity fall causing foot injury).

### 1.2.2 MAINTENANCE

Any damage to the SLD/DLD diverter should be repaired immediately.

Turn off the power and wait a couple of minutes before starting maintenance/inspection/repairs. Make sure you secure the power supply against being switched on again.

Only access the plant where access is allowed and follow safety notices. Always wear protective clothes and/or use safety equipment.

When replacing parts to the SLD/DLD diverter disassemble only the parts as specified in the manual.

Be careful for not getting your fingers caught in the SLD/DLD diverter.

Make sure you will mount covers and tighten screws properly after maintenance/inspection/repair.

### 1.3 SYMBOLS



**Warning:** Indicates an imminently hazardous situation which, if not avoided, will result in death or serious injury.



**Caution:** Indicates a potentially hazardous situation which, if not avoided, may result in minor or moderate injury and could cause property damage.



**Note:** In order to keep the machine in full performance, comply with all technical requirements for the correct use of the machine.



**Info:** additional information for optimizing and taking the full advantage of your machine.

**1.4 RISK ANALYSIS**

Hazard	Cause	Avoidance
Serious injury to the area of the spine/wrist	Excessive physical stress during manual lifting of the products	Use appropriate lifting equipment instead of manually lifting.
Serious injury to hands	Clamping of hands between moving objects  Catching of clothing/jewellery in moving machine parts during maintenance or operation	Do not touch the product when it is connected to a power source or when it is operating.  Use approved working clothes and remove all jewellery.
Serious injury to head	Catching of hair in moving machine parts during maintenance or operation	Bind long hair together and always use a hairnet.
Serious injury to body	Falling of unit loads while removing from the SLD/DLD diverter after breakdown/emergency stop.	Use of safety shoes (minimum Class SB) Use of safety gloves with grip coating Use of safety straps when lifting unit loads above 25kg.



**PRODUCT INFORMATION**

**2.1 TECHNICAL DATA SHEET**

<b>General Data</b>	
Voltage	DC24V
Controller	DC24V
Rated Motor Output Current / row	2.5A x 2 (ECO), 3.5A x 2 (Boost and Boost-8)
Available Starting Current / row	3.0A x 2 (ECO), 5.0A x 2 (Boost), 8.0A x 2 (Boost-8)
Diverter speed	0,1 – 2 m/s
Max. load capacity	35 kg – Max. load capacity is depending on the combination of speed & load
Operating ambient temperature	0°C to 40°C
Operating ambient humidity	Less than or equal to 90% (No condensation)
Noise level	<80dB – Noise level can vary due to surrounding conditions
Installation site	Indoors
<b>Dimensions</b>	
SW (Sorter width)	400mm, 600mm, 800mm and 1000mm (max. +50mm)
Length	SLD = 200mm / DLD = 400mm
α-angle	-90° up to +90°
Weight	20 – 73 kg Depending on size of diverter
<b>Wheel drive assembly</b>	
Wheel diameter	180mm
Roller diameter	58mm
Roller material	Plastic with PU cover
Roller bearing	Precision ball bearing 608-2RS
Wheel drive assembly motor	DC24V
Transmission belt for rollers in wheel	Poly-V PJ belt 214mm 2ribs
Transmission belt for wheel drive assy.	Poly-V PJ belt 559mm 4ribs
<b>Swivel Wheel drive</b>	
Swivel drive	DC24V
Swivel time	180° in 0,3s
Transmission belt for wheel	HTD 5M 630-9
Transmission belt for motor	HTD 5M 325-9

## 2.2 PRODUCT DESCRIPTION

The SLD/DLD diverter is used for diverting unit loads, preferably with smooth bottom surfaces, at different angles onto chutes to the right or to the left. It can also be used as a package aligner before final sorting.

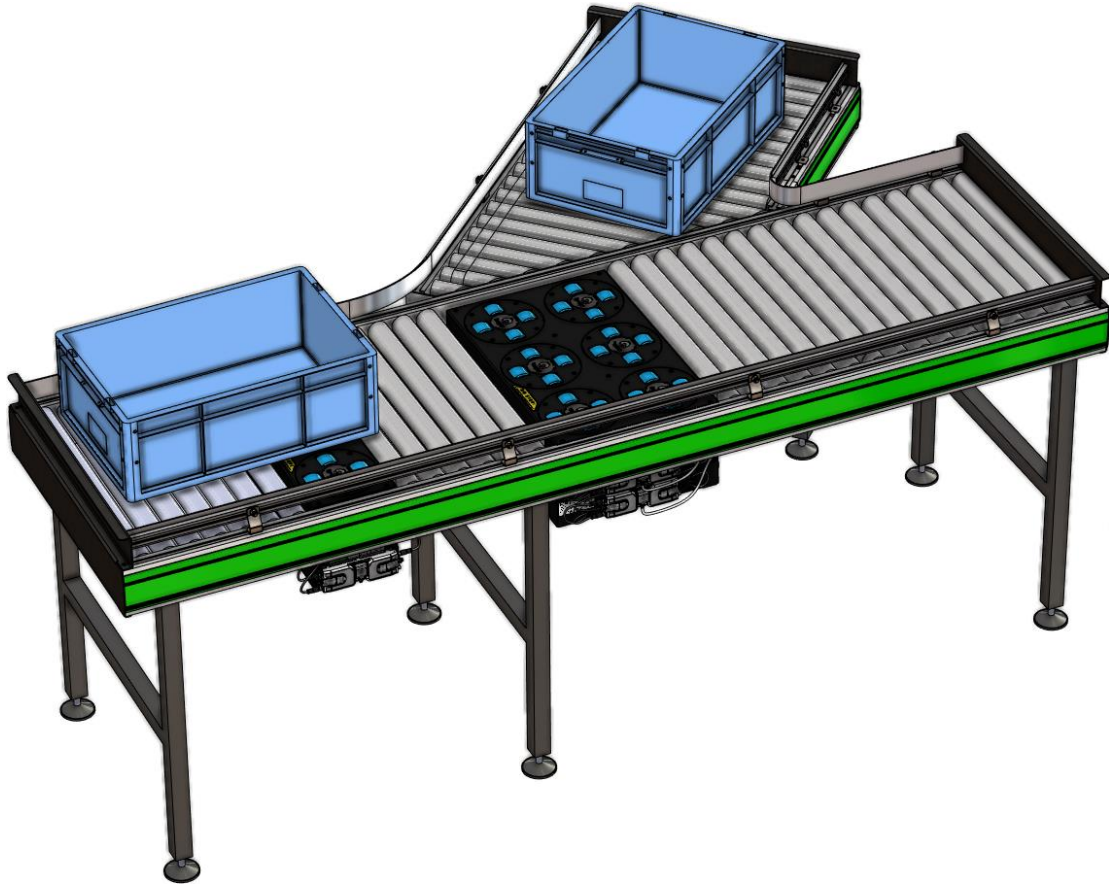

## 2.3 OPTIONS

The SLD/DLD diverter has a variety of options which will affect dimensions and weight. Apart from diverter speed and divert angles, which will not affect dimensions, the possible frame widths can differ. The options are 400mm with 2 wheel drive assemblies, 600mm with 3 wheel drive assemblies, 800mm with 4 wheel drive assemblies and the 1000mm with 5 wheel drive assemblies. All widths can be extended with 50mm to fit for example a 650mm frame work. The difference between the SLD and the DLD is the length. The SLD has a length of 200mm the DLD 400mm. The DLD has a double number of wheel drives compared to the SLD.

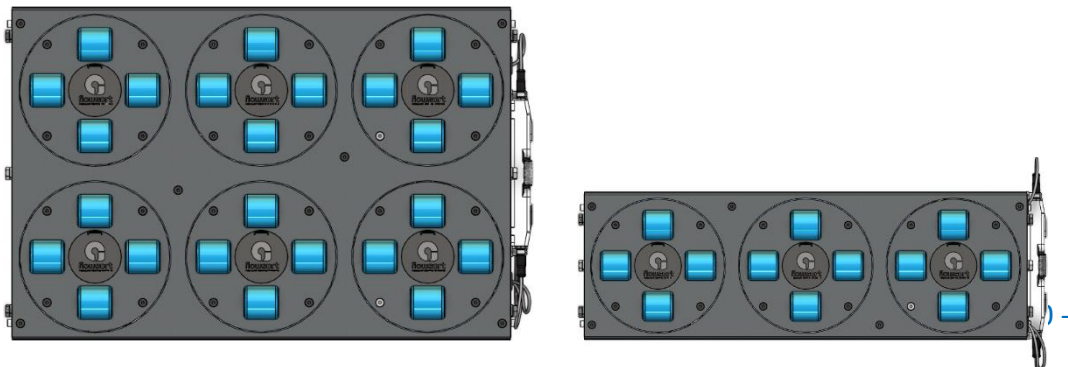

**PRECAUTIONS BEFORE USE**

**3.1 EXPLANATION PART NAMES**

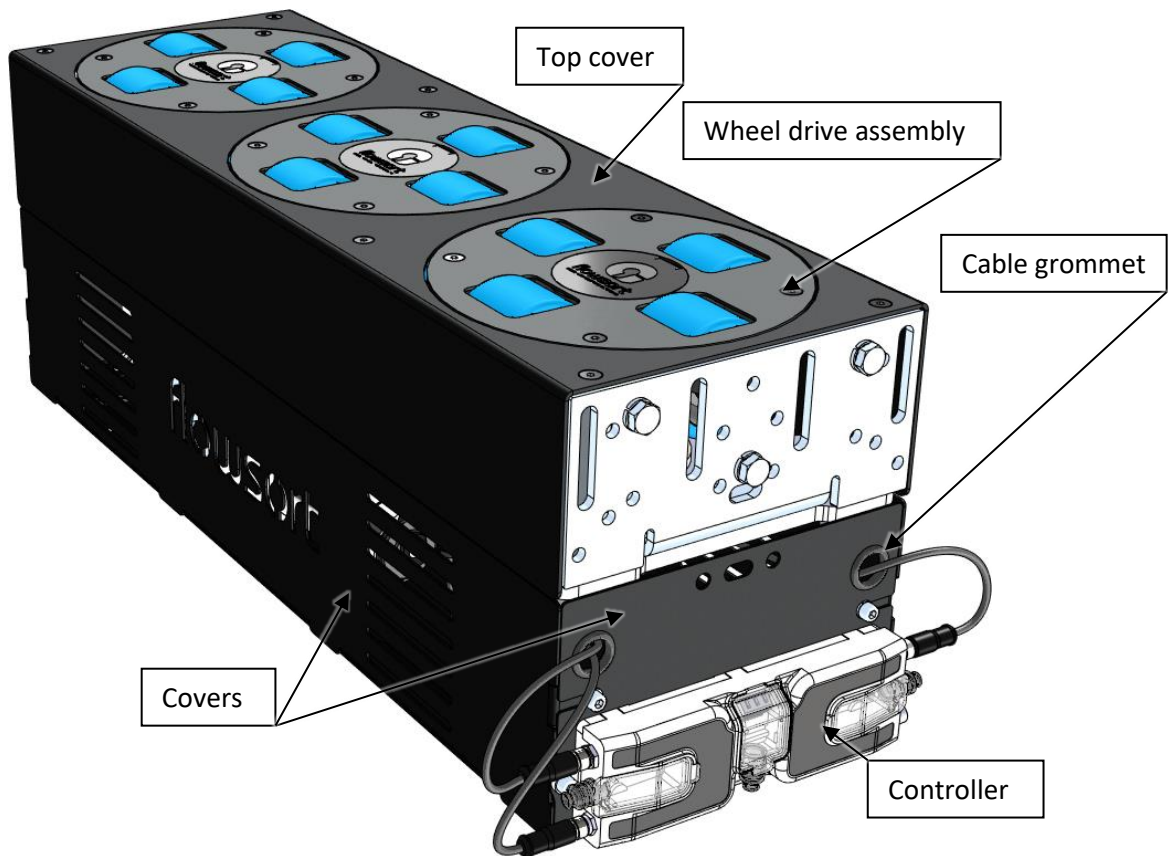

**3.2 ADDITIONAL DOCUMENTATION FOR APPLICATION**



- General and local rules for accident prevention.
- Law on the Protection of staff.
- Requirements for environmental protection.
- Compliance with established house rules.

**3.3 STAFF TRAINING**



- You have completed the required training and you are fully aware of the possible risks.
- You are aware of the predefined house rules and have been instructed by the responsible operator.
- You understand the contents of this documentation.

**3.4 SAFE OPERATION**



- Please ensure that there are no persons or obstacles in the danger areas.
- When there is a threat of danger make sure you shut down operation at once.
- Regular monitoring and maintenance keeps your factory ready for use and safe.
- Safety and hazard statements must be fully legible.
- Immediately correct any defects or damages.
- Wearing and using protective equipment.

## INSTALLATION

### 4.1 GENERAL RULES

Before starting assembly take the following into account:

- Make sure you install the SLD/DLD diverter as designed in the overall layout.
- Check packaging for damages before unpacking the SLD/DLD diverter.
- During unpacking make sure you do not damage the SLD/DLD diverter and you are using proper tooling. See crate for first instructions.
- Make sure you will align the system together with the rest of the system standing around it.
- Please make sure you clean the worksite after assembly and before testing. Do not leave any spare parts or tools in the work site and surrounding area, it can cause damages.
- Perform a full risk analysis of the entire installation as the 24V right angle diverter itself is not a complete system.

Assembly and installation can only be done by properly instructed personnel. This personnel must be under the supervision of a manager who is technically competent concerning the following:

- Knowhow concerning the SLD/DLD diverter and its use.
- The dangers in relation to the assembly of heavy machinery.
- The risks related to incorrect installation.
- The adjustments required for correct installation.

### 4.2 INSTALLATION

The installation manual provided by FlowSort B.V. is an overall guide line in how to install the modules. Always adapt the installation manual to the national and local safety rules and restrictions.

FlowSort B.V. will always deliver the SLD/DLD diverter pre-assembled. Installation on site only consist out of the following:

- Mounting into frame work
- Cable/wiring (24VDC and data)



***If any adjustments are made, both to the SLD/DLD diverter itself as to the position within the framework, then FlowSort B.V. will not take responsibility for the machinery because it represents unintended use of the SLD/DLD diverter. For wiring instructions please check <https://www.pulseroller.com/downloads>***



***Make sure that each module section is well supported before you mount the SLD/DLD diverter into the framework. After assembly do not move this framework as it could cause damages to the framework. After installation always mount the leg set to the floor or to a solid construction. It reduces movement/vibration during operation.***

### 4.3 LIFTING AND TRANSPORTATION OF THE DIVERTERS

The SLD/DLD diverter contains pre-mounted eye-bolts on the base plate to be used for lifting the modules. The eye-bolts are accessible after removing the top cover. The diverters can also carefully be transported by supporting the diverters from below.

Gently support the diverters from below to get to the right position. Make sure not to bump in the bottom covers or move the diverters sideways. Always pick the diverters up by the two side plates or by the eye-bolts.

*Lifting and transporting the diverters is at own risk and own responsibility.  
Be careful while moving the diverters over the ground and thru the air!*

**Step 1:**

Remove the M5x10 countersunk head screw and remove the top cover plate.

**Step 2:**

Lift the diverters by using the eye-bolts mounted on the base plate.

**Step 3:**

Place the top cover plate back and mount the M5x10 countersunk head screws.  
*Fasten the black M5x10 countersunk head screws in the top cover with only 3Nm!*

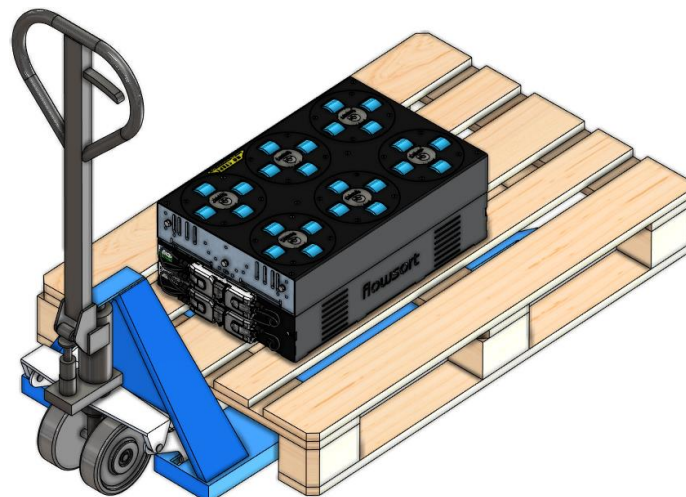

#### 4.4 ASSEMBLY/DISASSEMBLY SLD/DLD DIVERTER VS FRAMEWORK

The SLD/DLD diverter contains pre-mounted bolts on the side frame to be used for mounting into the frame work.

**Step 1:**

Remove the hexagon bolts M8x16 including spring lock washer at the side of the diverter.

**Step 2:**

Make sure that the framework has  $\varnothing 8.2$  holes corresponding to the holes of the diverter. Check TOR (top of roller) or TOB (top of belt) height to match the diverter height.



*We recommend you to use a +2mm height of the diverter wheels relative to the TOR/TOB. The distances between the rollers should be equal on both sides. The roller may not hit the diverter cover otherwise it could get damaged. If it is not aligned perfectly then untighten the diverter and move the diverter until you have the same gap between the rollers on both ends of the diverter.*

**Step 3**

Lift up the SLD/DLD diverter with appropriate lifting equipment and align the holes from the SLD/DLD diverter with the framework. Mount the M8x16 hexagon bolt with the spring lock washer.

**Step 4**

Disassembly can be done by repeating the steps in reverse order.

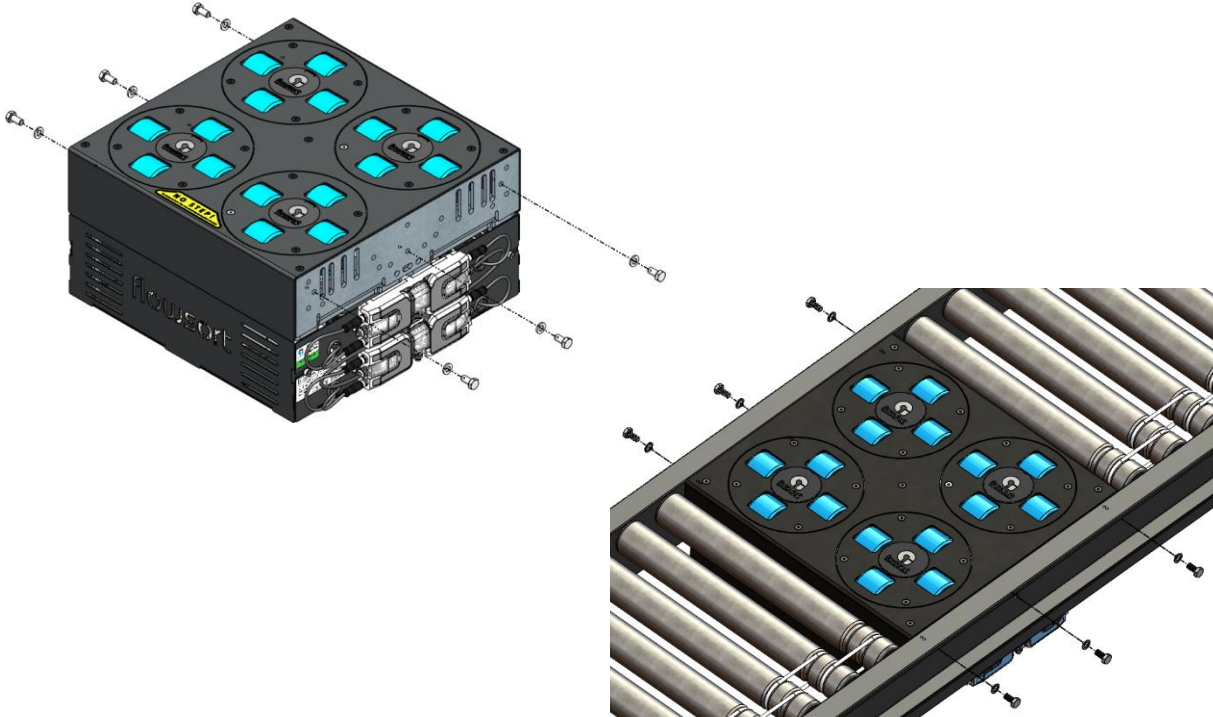

#### 4.5 WIRING AND GROUNDING OF THE SLD/DLD DIVERTER

The control card can be found at the right side or the bottom of the SLD/DLD diverter module. Make sure all cables are connected properly. Failure to do so may lead to malfunction.

Sensors and motors are already pre-cabled during production. Flowsort will also provide an UTP-cable between the two controllers in a DLD. Wiring the drive control card, like power supply and PLC-communication, has to be done according to the Integration Manual. Flowsort will provide the integration manual on order or on request.

When using the diverters, a higher electrical voltage build-up is generally not to be expected. However, the dust and the high speeds on the belt can cause a voltage build-up. Therefore Flowsort states that each diverter is connected to a main ground of the electrical connection according to DIN VDE 0100 (VDE 0100). The best is to do ground the base plate of the diverters.

This is a protection against possible electrical sparking, dust accumulation and it also protects the motor electronics from overvoltage.

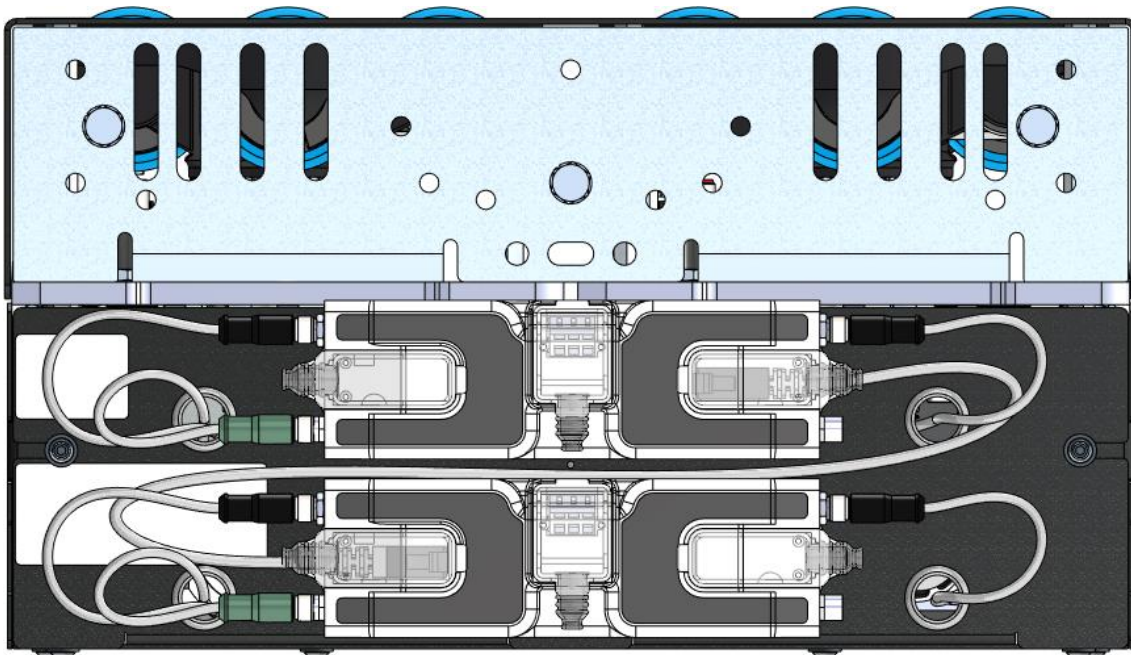

## OPERATION

### 5.1 FIRST CHECKS BEFORE OPERATING



- When connecting the SLD/DLD diverter to another system, you will have to perform a risk analysis of the entire installation.
- Always check the installed modules for damages before starting operation. If there are visible damages please inform operating supervisor immediately. Do not start operation, see maintenance.
- Check the area for material that should not be there, and remove this when it's there (packaging material, tools, debris, etc.).
- Check if all signs/restrictions are in place (max. load capacity and restriction for use).
- Check if all personnel is properly instructed before working with or near the SLD/DLD diverter.

### 5.2 DURING OPERATION



Shut down the whole system if any of the following occurs:

- A broken or damaged component.
- Damage to structural components such as frame, side guiding and leg set.
- Doubtful noise from any of the components.
- Liquids are on the systems.
- Unit loads on the conveyor system are getting stuck.

### 5.3 IN CASE OF AN ACCIDENT



- Press in the emergency stop of the system where the SLD/DLD diverter is located.
- Secure the area and set up appropriate signage.
- In the event of an accident: provide first aid and let someone else call the emergency services.
- Inform qualified personnel and/or operating supervisor.
- Have the system repaired by qualified maintenance personnel.
- Do not use the SLD/DLD diverter until it has been approved by qualified maintenance personnel.

### 5.4 SET-UP DIVERTING ANGLE

The diverting angles can be set between  $-90^\circ$  and  $+90^\circ$  in relation to its start position which is  $0^\circ$ . The diverter has an inductive sensor for its home position. Setting up the angle will be done in the software. A possible set-up is  $-45^\circ$  and  $+30^\circ$  depending on the chutes. Please contact FlowSort B.V. for the right function blocks. The function blocks are available in multiple brands of PLC-suppliers (i.e. Siemens, Beckhoff, Allen Bradley and others).



**MAINTENANCE**

**6.1 MAINTENANCE INTERVALS**

Damage can occur if maintenance is not performed as planned. If the maintenance intervals are not followed as suggested, the warranty expires.

Flowsort has defined the following maintenance intervals:

Working hours per day	Interval per
0 - 12	3 months
12 - 24	2 months

During these maintenance periods the SLD/DLD diverter should be disconnected from the power supply. Please clean and look closely for wear during inspection. If errors are found during inspections, they must be corrected immediately.

**6.2 GENERAL MAINTENANCE INFORMATION**



Clean the outside of the SLD/DLD diverter with a dry cloth. Do not use aggressive cleaning agents as it could affect the components resulting in a possible oxidization of the parts. Never use water for cleaning!

Secure the working area and shut down the system and apply appropriate signage. Make sure nobody can start up the system during maintenance.

Make sure maintenance is carried out by qualified personnel who are familiar with the instruction manual and procedures.

Wear personal protective equipment.

If in doubt, contact the supplier or manufacturer of the parts.

**6.3 CLEANING THE BLUE WHEELS**

Due to dust and small splinters of damaged products (i.e. cardboard dust, loosened tapes, etc.) the blue rollers in the discs can get dirty. The dirtiness on the blue rollers can reduce the grip on the transported products. With real dirt on the rollers, the sortation movement can be affected. Therefore, the blue rollers need to be cleaned with the following intervals:

**Clean the blue wheels after: 1000 hours of rotation**

To clean the blue wheels, use a degreaser or another liquid that does not affects the blue TPU of the blue wheels.

**6.4 SPARE PARTS**

All electronic and drive parts are from preferred suppliers. Please check the appendix or have a look on their website for additional maintenance and cleaning information.

Please have a look at our recommended spare part list in this document at paragraph 8.7.

6.5 INSPECTION SLD/DLD DIVERTER

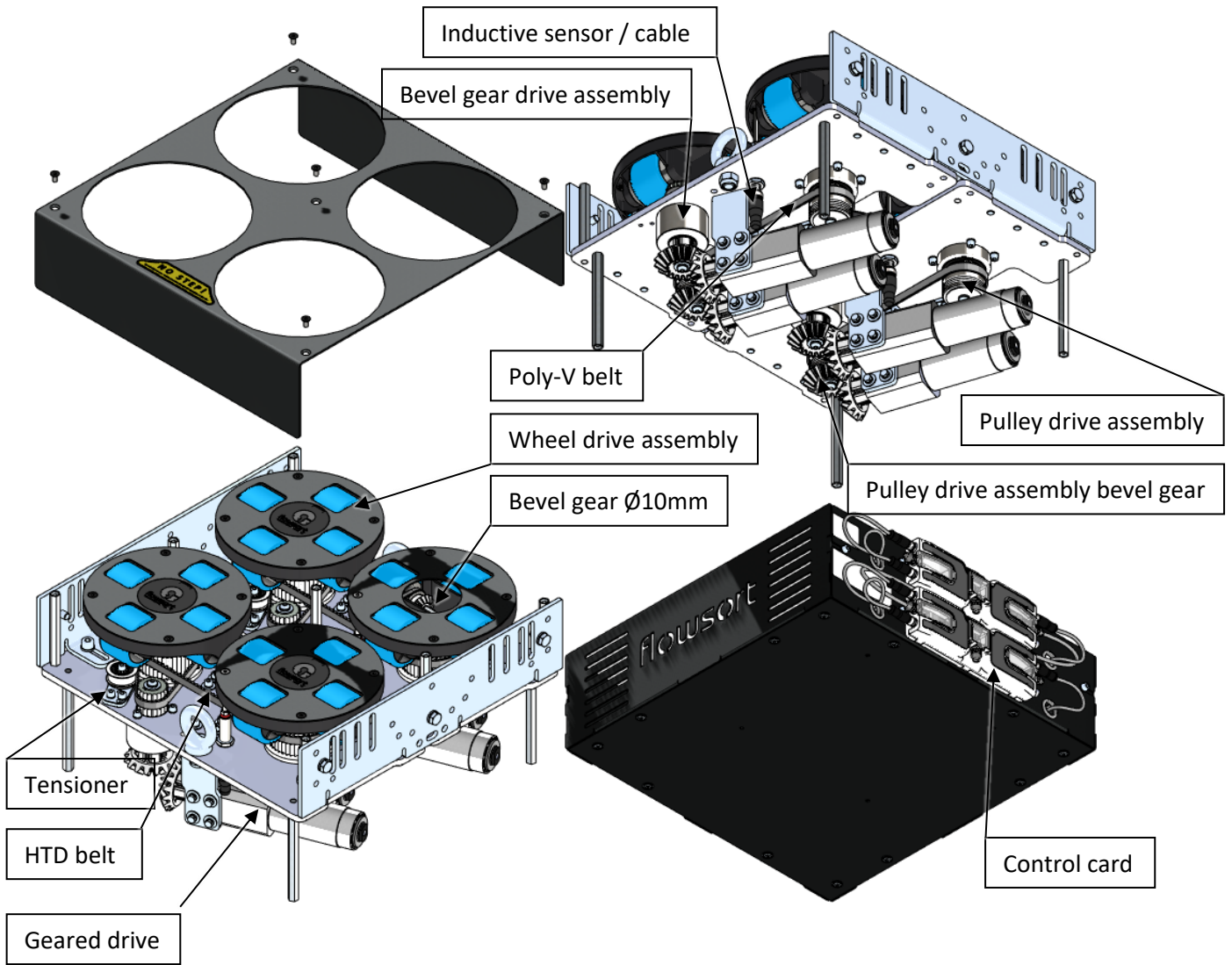

Item	Inspection	Outcome	Action to execute
Geared drives	Visual check	Damaged cable	Replace geared drive

	Sound check Mounting check	Abnormal/scratchy noise Bolts are too loose Damaged bevel gear	Replace geared drive Tighten bolts with torque wrench Replace the bevel gear
Bevel gear drive assembly	Visual check	Damaged bevel gear Leaking bearings	Replace the assembly Replace the assembly
	Sound check	Abnormal/scratchy noise	Replace the bevel gear
Wheel drive assemblies	Visual check	Damaged wheels Leaking bearings	Replace wheel drive assembly Replace wheel drive assembly
	Sound check	Abnormal/scratchy noise	Replace wheel drive assembly
Pulley drive assemblies	Visual check	Damaged tooth or poly-V wheel	Replace tooth or poly-V wheel
	Sound check	Abnormal/scratchy noise	Replace pulley drive assembly
Control cards	Visual check	No power	Check power supply
		Loose cables	Fasten loose cables and check wiring
		Dirtiness	Clean control card
		Damaged	Replace control card
Bevel gears	Visual check	Damaged bevel gear	Replace complete wheel drive assembly
Poly-V wheels	Visual check	Damaged poly-V wheel	Replace complete wheel drive assembly
Inductive sensors/cables	Visual check	LED off	Check wiring and/or cable connection. Check power supply
	Mounting check	Sensor too loose	Tighten nuts Replace sensor
HTD belts	Visual check	Damaged/broken belt	Replace HTD belt
Poly-V belts	Visual check	Damaged/broken belt	Replace poly-V belt
Tensioners	Visual check	Damaged	Replace tensioner
	Sound check	Abnormal/scratchy noise	Replace tensioner

## 6.6 REMOVAL AND REPLACEMENT OF PARTS

The parts in the diverters need to be repaired and replaced as soon as possible. Make sure the SLD/DLD diverter is disconnected from the power supply during cleaning, maintenance and/or replacements.

### 6.6.1 COVER REMOVAL/REPLACEMENT

Make sure the SLD/DLD diverter is disconnected from the power supply during cleaning, maintenance and/or replacements.

#### Step 1

Disconnect all cables to the control card. Please keep in mind how the cables are connected to the control card.

#### Step 2

Remove the black M5x10 countersunk head screw and remove the top cover plate.

#### Step 3

Remove the black M5x8 screws at the bottom and loosen the screws on both sides. Remove the bottom cover side plate to get access to the inside. Put all bolts in a bag not to lose them.

#### Step 4

Replacing the covers can be done by repeating the steps in reverse order.

*Fasten the M5x10 countersunk head screws in the top cover with only **3Nm!***

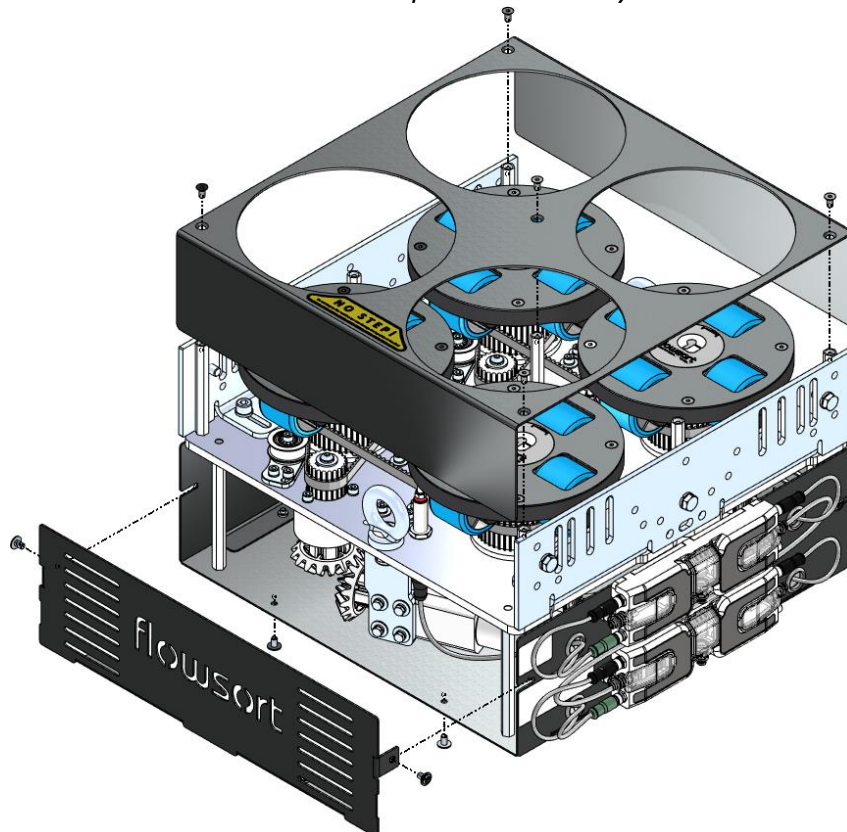

### 6.6.2 WHEEL GEARED DRIVE REMOVAL/REPLACEMENT

Make sure the SLD/DLD diverter is disconnected from the power supply during cleaning, maintenance and/or replacements.

#### Step 1

Loosen the motor cable from the controllers so the motor is not powered any more.

#### Step 2

Remove the four M5x16 hexagon head screws, M5 lock washers that are holding the geared drive. Remove the geared drive from the plate. Put the fasteners in a bag not to lose them.

#### Step 3

Remove the bevel gear, large washer, M6 spring lock washer, M6 bolt and the key from the geared drive.

#### Step 4

Take a new geared drive and assemble the key, bevel gear, large washer, M6 spring lock washer and M6 bolt in written order.

#### Step 5

Tighten the geared drive with the four M5x16 hexagon head screws, M5 lock washers to the plate. Tightening torque: 3,59Nm

#### Step 6

See paragraph 6.6.7 setting the bevel gear gap for motors.  
Reconnect the cables to the control card.

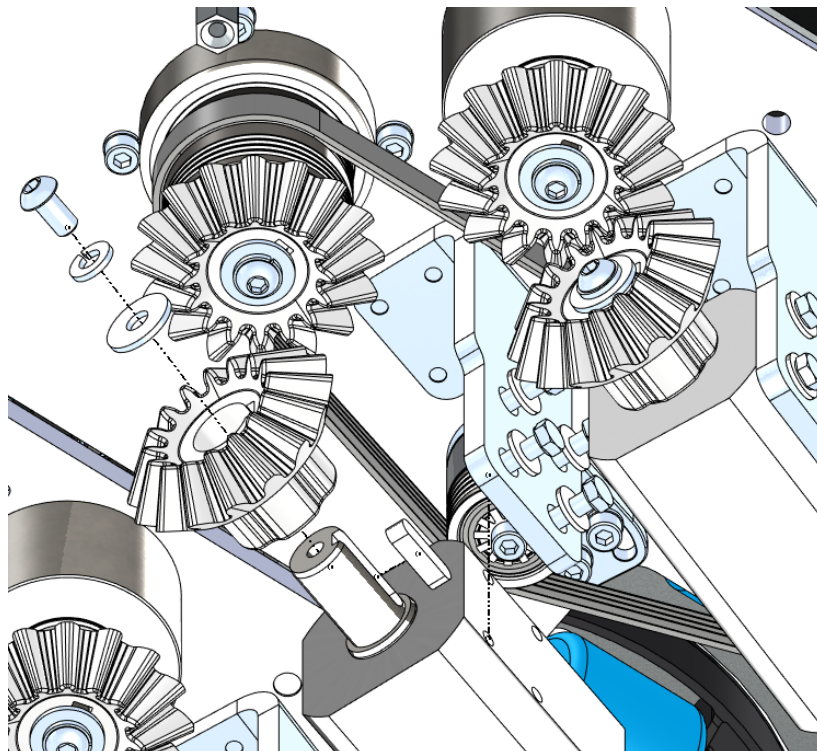

### 6.6.3 WHEEL DRIVE ASSEMBLY REMOVAL/REPLACEMENT

Make sure the SLD/DLD diverter is disconnected from the power supply during cleaning, maintenance and/or replacements.

#### Step 1

Remove the cover cap in the middle of the wheel drive assembly.

#### Step 2

Use an impact wrench in order to remove the four M5x20 hexagon socket head cap screws.

#### Step 3

Remove the wheel drive assembly.

#### Step 4

Replacing the wheel drive assembly can be done by repeating the steps in reverse order. Tightening torque: 3,8Nm

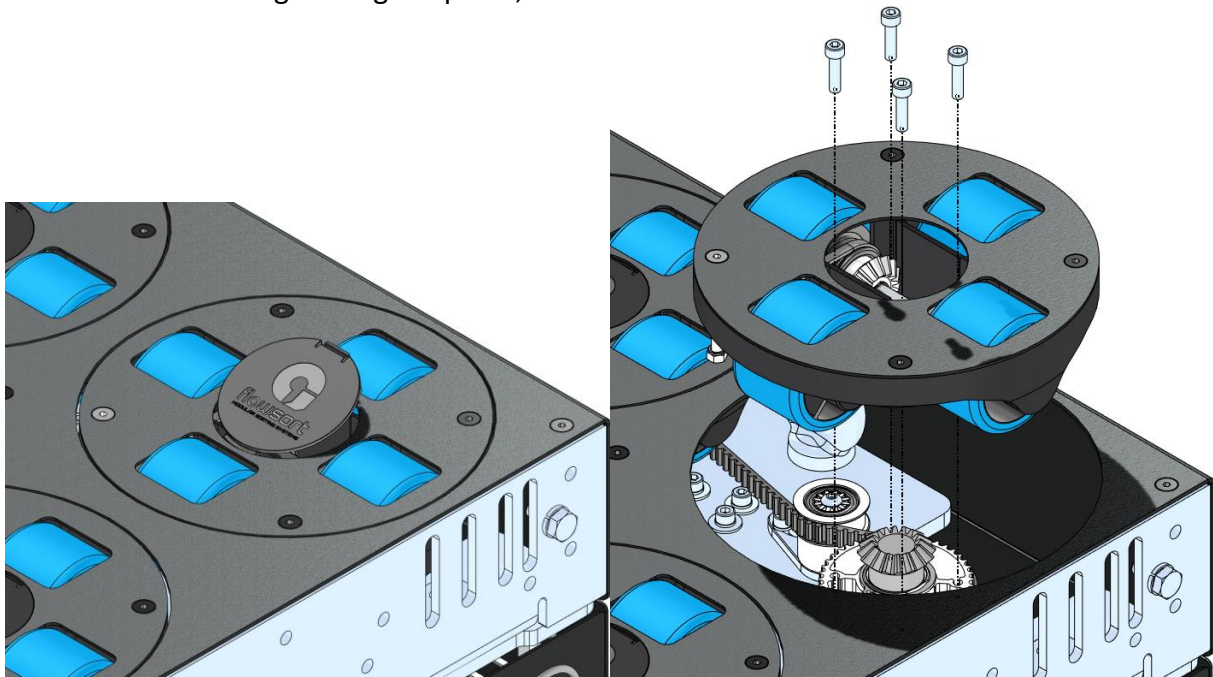

### 6.6.4 PULLEY DRIVE ASSEMBLY REMOVAL/REPLACEMENT

Make sure the SLD/DLD diverter is disconnected from the power supply during cleaning, maintenance and/or replacements.

Before starting with step 1 see paragraph 6.6.1 cover removal/replacement and paragraph 6.6.3 wheel drive assembly removal/replacement.

#### Step 1

Remove the timing belts on the top side of the SLD/DLD diverter that are connected to the pulley drive assembly to be removed.

Take of the tension of the tensioners, it makes it easier to remove the belt.

#### Step 2

Remove the poly-V belts on the bottom side of the SLD/DLD diverter that are connected to the pulley drive assembly to be removed. Take of the tension of the tensioners it makes it easier to remove the belt.

#### Step 3

Remove the four M5x14 socket head screws and the spring lock washers connecting the pulley drive assembly to the baseplate.

#### Step 4

In case of pulley drive assembly with bevel gear the plastic gear must be removed from the poly-V pulley.

#### Step 5

Remove the pulley drive assembly from the baseplate.

#### Step 6

Replacing the pulley drive assembly can be done by repeating the steps in reverse order. See paragraph 6.6.12 HTD belt removal/replacement for correct belt replacement.

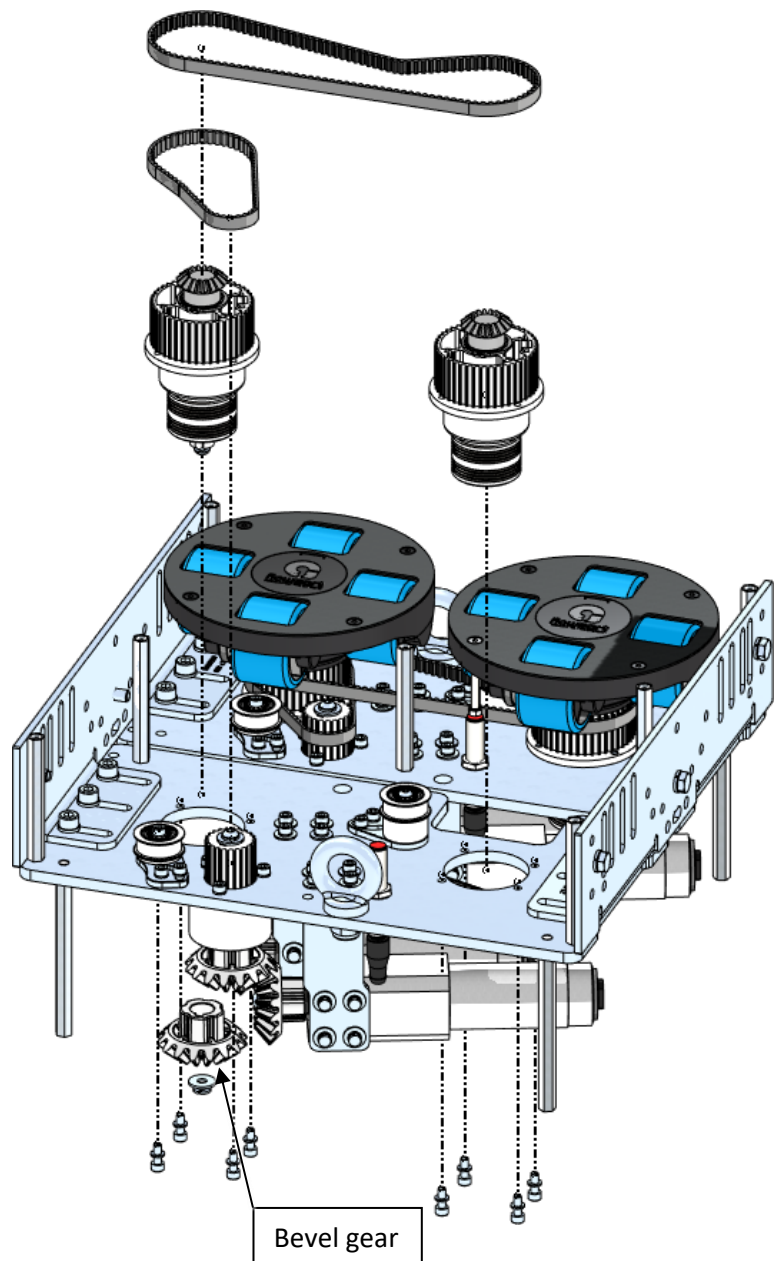

### 6.6.5 SWIVEL GEARED DRIVE REMOVAL/REPLACEMENT

Make sure the SLD/DLD diverter is disconnected from the power supply during cleaning, maintenance and/or replacements.

Before starting with step 1 see paragraph 6.6.1 cover removal/replacement.

#### Step 1

Loosen the motor cable from the controllers so the motor is not powered any more.

#### Step 2

Remove the four M5x16 hexagon head screws, M5 lock washers that are holding the geared drive. Remove the geared drive from the plate. Put the fasteners in a bag not to lose them.

#### Step 3

Remove the bevel gear, large washer, M6 spring lock washer, M6 bolt and the key from the geared drive.

#### Step 4

Take a new geared drive and assemble the key, bevel gear, large washer, M6 spring lock washer and M6 bolt in written order.

#### Step 5

Tighten the geared drive with the four M5x16 hexagon head screws, M5 lock washers to the plate. Tightening torque: 3,59Nm

#### Step 6

See paragraph 6.6.7 setting the bevel gear gap for motors.

Reconnect the cables to the control card.

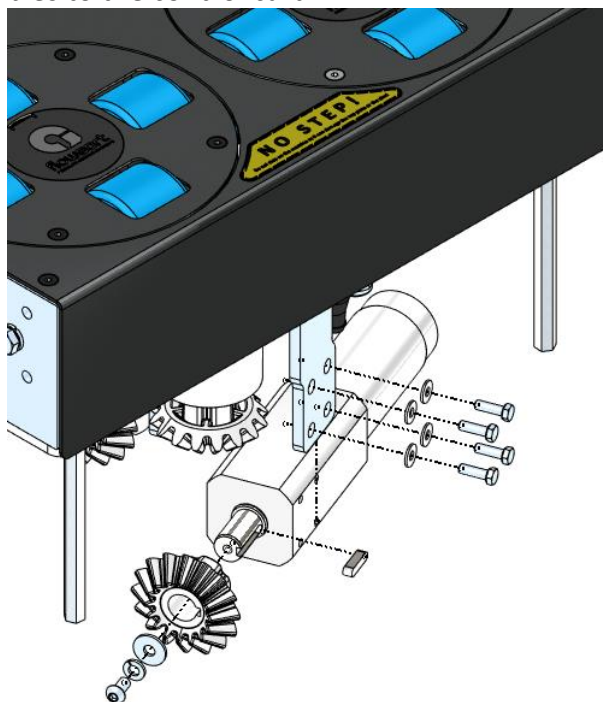



### 6.6.6 BEVEL GEAR ASSEMBLY REMOVAL/REPLACEMENT

Make sure the SLD/DLD diverter is disconnected from the power supply during cleaning, maintenance and/or replacements.

Before starting with step 1 see:

- paragraph 6.6.1 cover removal/replacement
- paragraph 6.6.5 swivel geared drive removal/replacement **Step 1** and **2**
- paragraph 6.6.12 **Step 1**

#### Step 1

Remove the three M5x16 socket head screws, M5 spring lock washers that are holding the bevel geared drive assembly. Remove the assembly from the base plate to the bottom. Put the fasteners in a bag not to lose them.

#### Step 2

Take a new bevel gear drive assembly and assemble the M5 screws, spring lock washers, belt, belt tensioner, in written order.

#### Step 3

See paragraph 6.6.7 setting the bevel gear gap for motors.

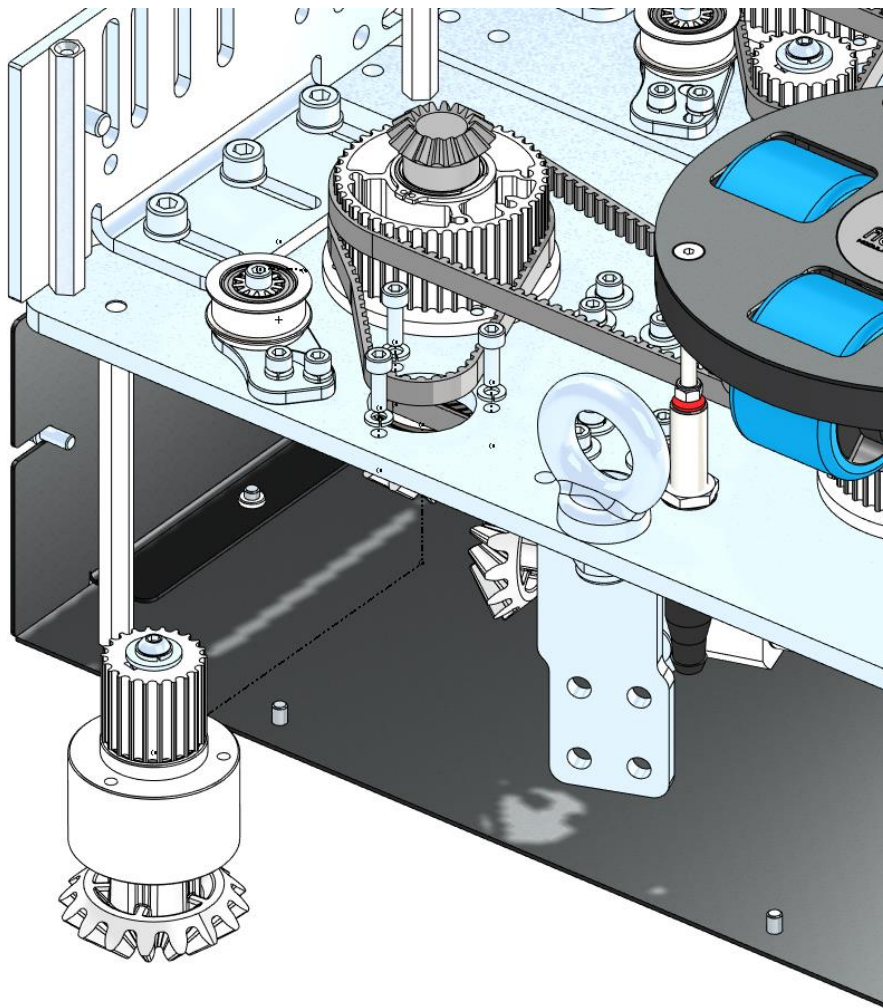

### 6.6.7 SETTING THE BEVEL GEAR GAP FOR MOTORS

Make sure the SLD/DLD diverter is disconnected from the power supply during cleaning, maintenance and/or replacements.

Before starting with step 1 see:

- paragraph 6.6.1 cover removal/replacement

For the long lifetime and noiseless operation, it is essential to get the bevel gears aligned relative to each other. Both the motor - bracket connection and the base plate - bracket connection are adjustable by 3 degrees of freedom. Mounting distance error, offset error and shaft angle error must be minimized to avoid excessive noise and wear.

- Motor – bracket:

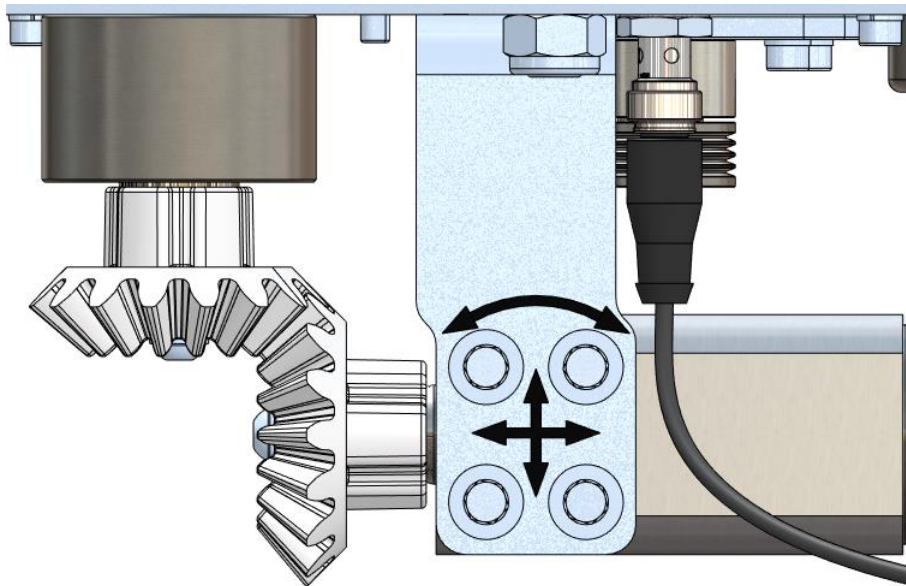

- Base plate – bracket:

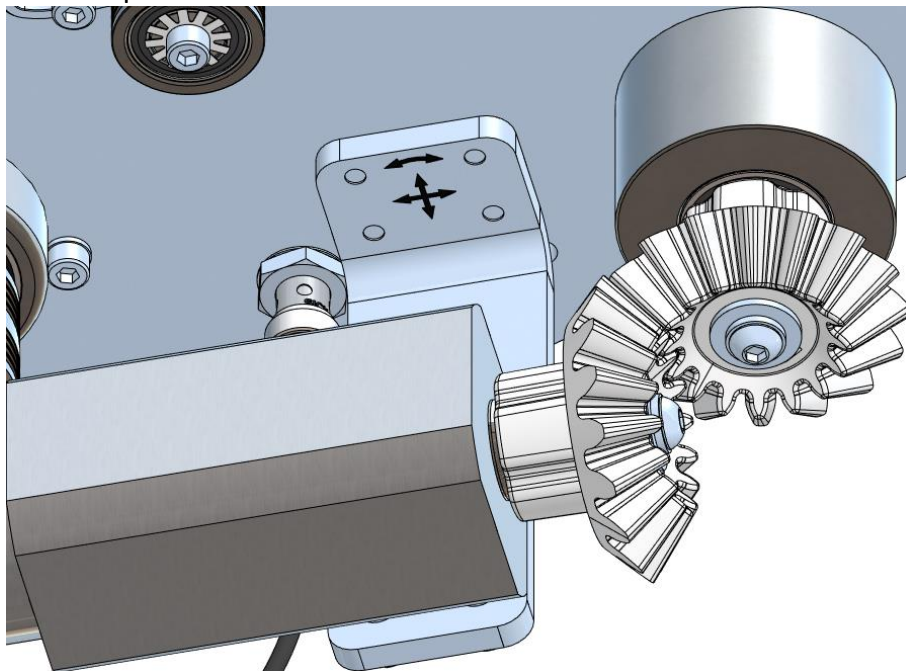

When replacing the motor make sure that 0,1mm backlash is provided between the gears. Typically the thickness of an office paper.

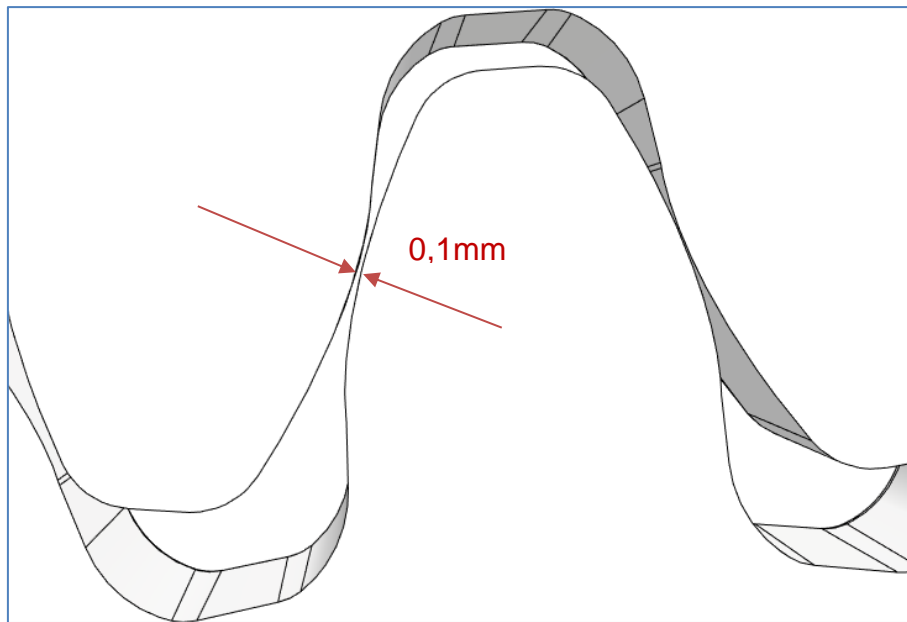

When assembled correctly, the contact will occur on both gears in the middle of the flank and center of face width but somewhat closer to the toe. Contact pattern can be checked by gear marker paint.

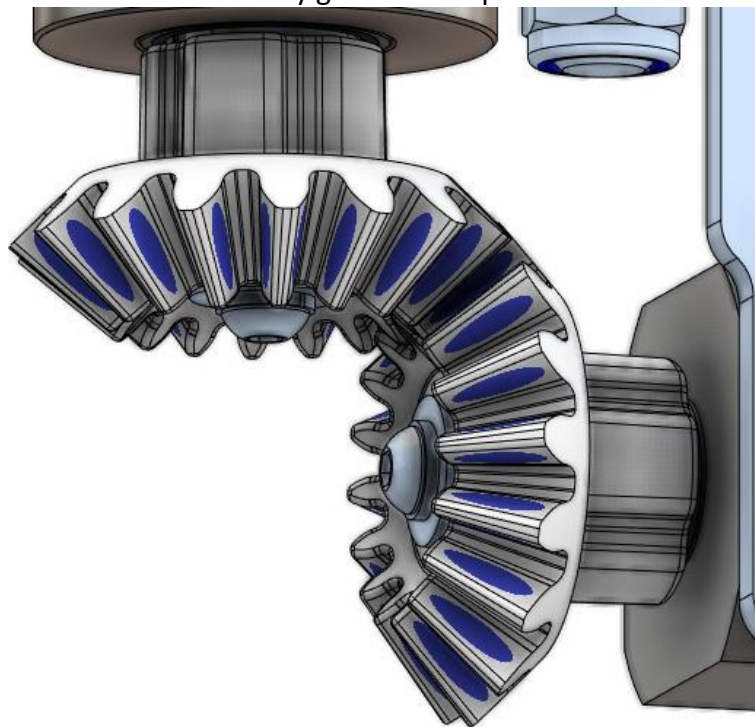

Flowsort can provide a tool for easier adjustment. Using the tool, the position of the bevel gears can be adjusted faster and more reliably. In this case marker paint is not needed either. Tool nr.: **V000082**

**Step 1**

Remove the bevel gear screws and loosen up a little bit all the 8 screws of the motor bracket to make it free to move.

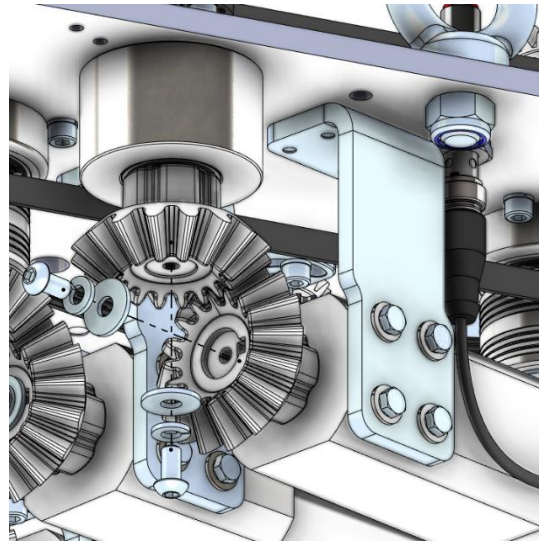

**Step 2**

Mount the tool on both bevel gears. This will align them into the correct relation.

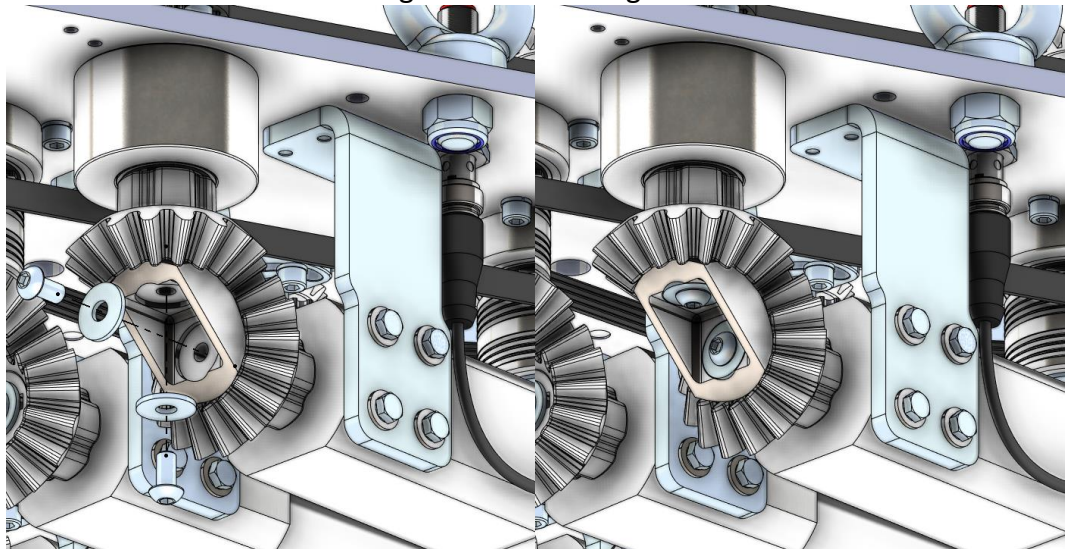

**Step 3**

Tighten up all the 8 screws of the motor bracket.

**Step 4**

Remove the tool and mount the flat washers, spring lock washers and screws of the bevel gears back as they were placed originally.

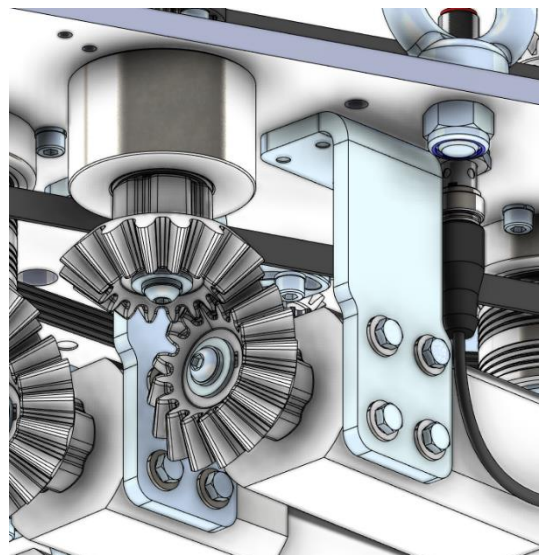

### 6.6.8 CONTROL CARD REMOVAL/REPLACEMENT

Make sure the SLD/DLD diverter is disconnected from the power supply during cleaning, maintenance and/or replacements.

#### Step 1

Disconnect all cables to the control card. Please keep in mind how the cables are connected to the control card.

#### Step 2

Untighten the two M5x12 socket head screws holding the control card.

#### Step 3

Replacing the control card can be done by repeating the steps in reverse order.

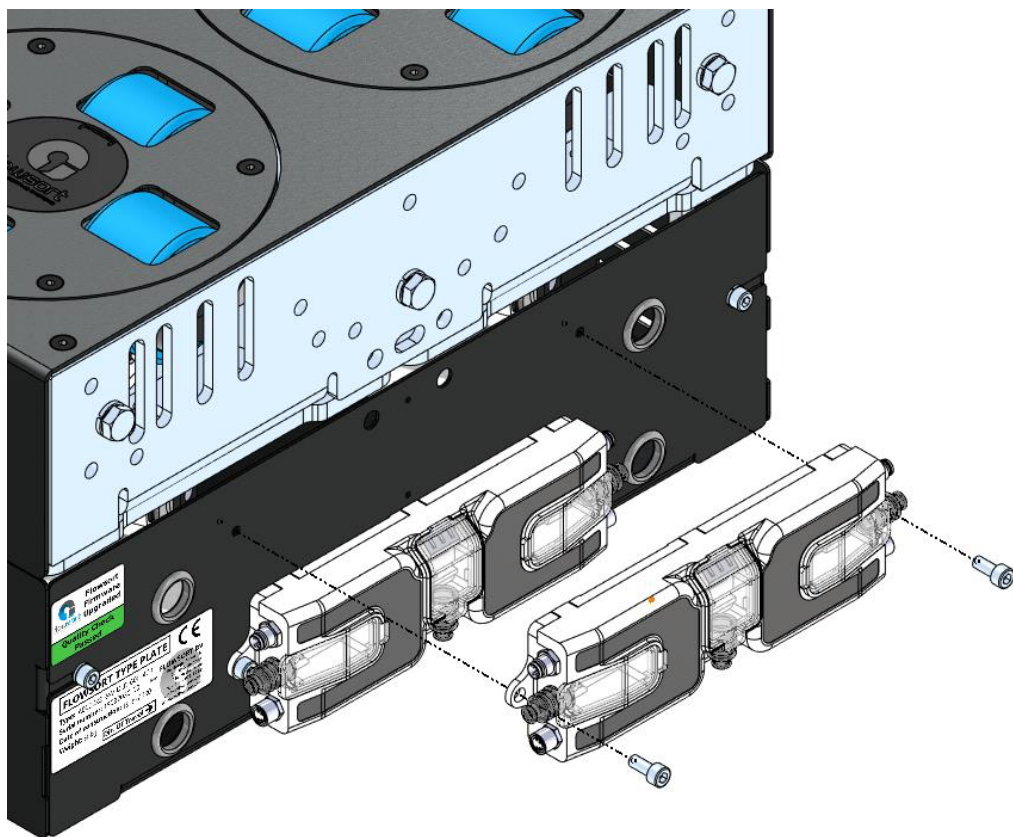

### 6.6.9 BEVEL GEAR REMOVAL/REPLACEMENT

Make sure the SLD/DLD diverter is disconnected from the power supply during cleaning, maintenance and/or replacements.

Before starting with step 1 see paragraph 6.6.3 SLD/DLD diverter wheel drive assembly removal/replacement.

#### Step 1

Remove tooth wheel by pulling the tooth wheel upwards. You can do this with your hands but in some occasions a screwdriver can be useful. You then place the screwdriver under the tooth wheel and push it up by leverage.

#### Step 2

Remove the key 3x3x10 out of the tooth wheel and place this back on the shaft of the pulley drive assembly.

#### Step 3

Place the new tooth wheel on the shaft. Make sure key way is in line with the key on the shaft. Push the tooth wheel down the shaft until it stops moving.

#### Step 4

Replace the wheel drive assembly, see paragraph 6.6.3 SLD/DLD diverter wheel drive assembly removal/replacement.

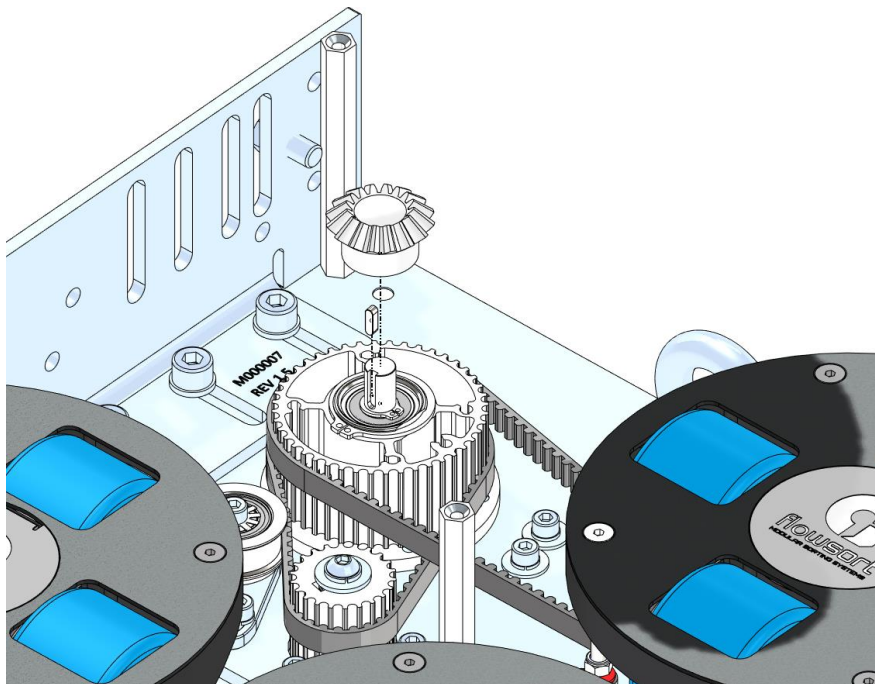

### 6.6.10 INDUCTIVE SENSOR REMOVAL/REPLACEMENT

Make sure the SLD/DLD diverter is disconnected from the power supply during cleaning, maintenance and/or replacements.

Before starting with step 1 see paragraph 6.6.1 SLD/DLD diverter cover removal/replacement and paragraph.

#### Step 1

Disconnect the sensor cable by turning the nut counter clockwise.

#### Step 2

Use two wrenches for untighten the two M12 nuts holding the inductive sensor on the base plate.

#### Step 3

Replacing the inductive sensor or sensor cable can be done by repeating the steps in reverse order. The distance between the inductive sensor and the nut underneath the sensor disc has to be set between **2 - 4 mm**. Make sure that after replacing the sensor cable it does not come close to the gears or belts. Tighten the sensor cable with tyrapas again.

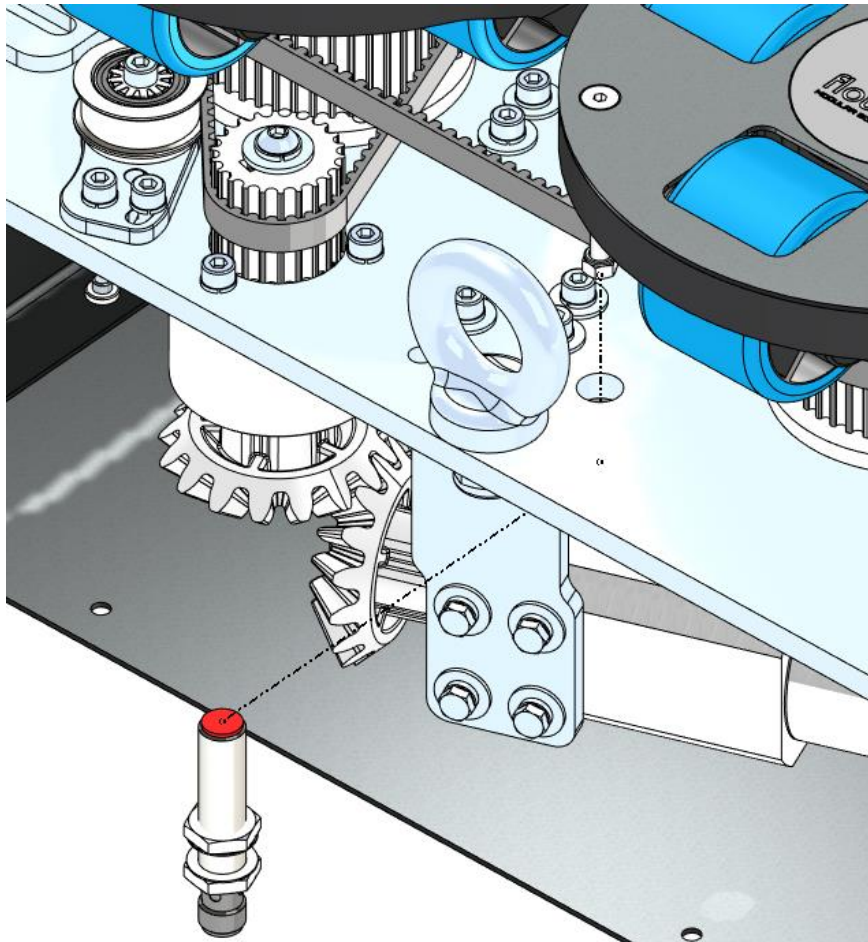

### 6.6.11 TENSIONER REMOVAL/REPLACEMENT

Make sure the SLD/DLD diverter is disconnected from the power supply during cleaning, maintenance and/or replacements.

Before starting with step 1 see paragraph 6.6.1 SLD/DLD diverter cover removal/replacement and paragraph 6.6.3 SLD/DLD diverter wheel drive assembly removal/replacement.

#### Step 1

Release the tension on the belt by untightening the M5x12 socket head screws including spring lock washers holding the tensioner on the base plate.

#### Step 2

Remove both M5x12 socket head screws including spring lock washers from the tensioner. Now you can remove the tensioner.

#### Step 3

Replacing the tensioner can be done by repeating the steps in reversed order. At the top side of the diverter you have to align the pulley drive assembly and its timing belt before replacing the tensioner.

See paragraph 6.6.12 SLD/DLD diverter timing belt removal/replacement.

To put the right tension on the belt, see paragraph 6.7 Tensioning the belts.

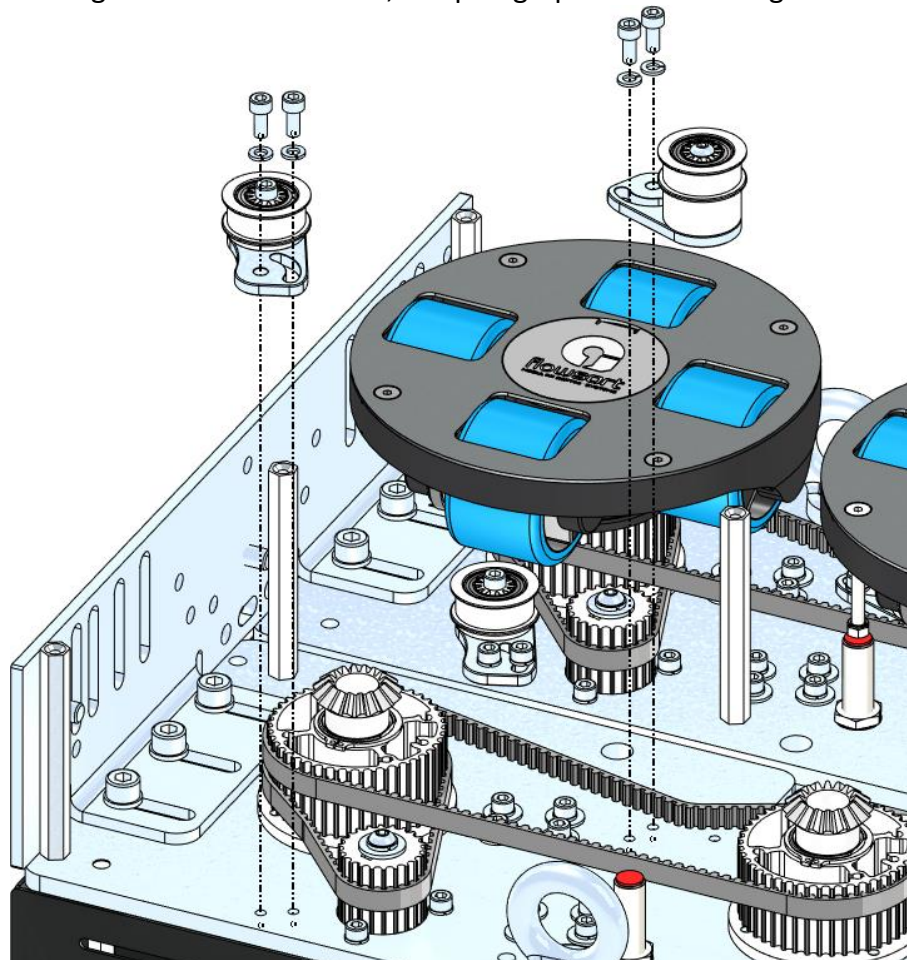



### 6.6.12 TIMING BELT REMOVAL/REPLACEMENT

Make sure the SLD/DLD diverter is disconnected from the power supply during cleaning, maintenance and/or replacements.

Before starting with step 1 see paragraph 6.6.1 cover removal/replacement and paragraph 6.6.3 wheel drive assembly removal/replacement. When it comes to the tensioner and the tensioner wheel isn't visible, read paragraph 6.6.10 tensioner removal/replacement too.

#### Step 1

Release the tension on the belt by untightening the M5x12 socket head screws including spring lock washers holding the tensioner on the base plate.

#### Step 2

Replacing the belt can be done by repeating the steps in reversed order. At the top side of the diverter you have to align the pulley drive assemblies during timing belt replacement. Otherwise your wheel drive assemblies are not standing in the same position. This can be done by placing two shafts (*max Ø4mm*) in the centering hole fixing the pulley wheel drives and then adding the timing belt. To put the right tension on the belt, see paragraph 6.7 Tensioning the belts.

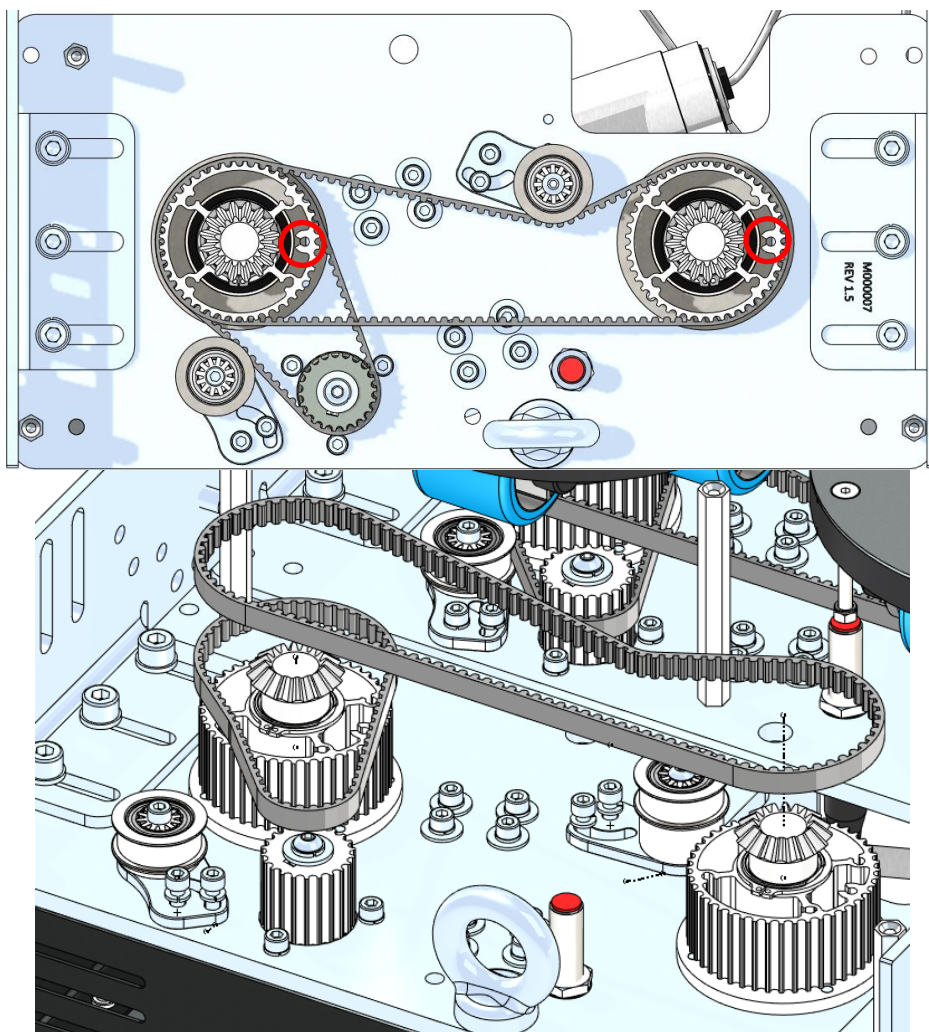

### 6.6.13 SLD/DLD WHEEL REPLACEMENT IN WHEEL DRIVE ASSEMBLY

Before starting with step 1 see paragraph 6.6.3. SLD/DLD diverter wheel drive assembly removal/replacement.

#### Step 1

Remove cover plate of the wheel drive assembly by undoing the M5 countersunk screws and M5 self-clinching nuts.

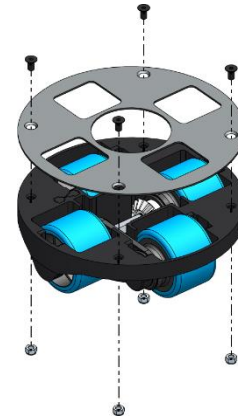

#### Step 2

Push all the wheels out from the housing. Can be done by pushing the blue wheels from below.

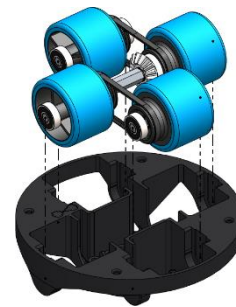

#### Step 3

Separate the wheels and poly-V belts.

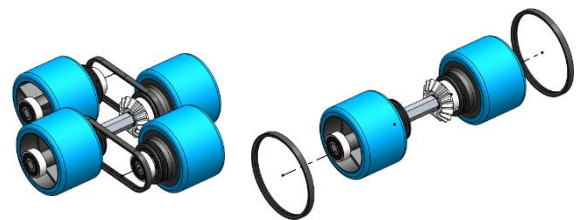

#### Step 4

Put everything back together in reverse order. Make sure that the double wheel assembly is in correct orientation of the bevel gear! There is an indicator contour embossed into the housing which shows the top view of the double wheel assembly.

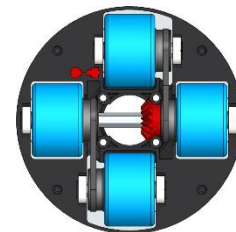

Do not hit the wheels to click them into the housing! It can cause damage to the bearings.

Press them gently until they all click into place!

## 6.7 TENSIONING THE BELTS

Make sure the SLD/DLD diverter is disconnected from the power supply during cleaning, maintenance and/or replacements.

The diverters are equipped with both HTD timing belts and poly-V belts. The HTD timing belts are used on top of the base plate for the disc-rotation. The poly-V belts are mounted underneath the base plate for the rotation of the blue wheels in the discs, the transportation. These belts need to be set to the right tension and these should also be checked after 3 months of running.

### 6.7.1 TENSIONING TOOL

To be sure that the belts are tensioned in the right way, a tensioning tool should be used.

Digital force gauge:



### 6.7.2 TENSIONING THE HTD TIMING BELTS

The HTD timing belts are used on top of the base plate for the disc-rotation. There are two belts with different lengths used in the diverters; the 325mm and the 630mm long belts.

The 325mm belt is placed over the geared drive with a low flat tensioner. The 630mm is used between all the other pulley drive assemblies on the top side of the base plate. The first tensioner on the first 630mm belt is the high one with the flat surface. Every next pulley drive assembly will get an additional 630mm belt with the right tensioner. The tensioners will change every next time from high to low and vice versa.

### 6.7.3 TENSIONING THE HTD TIMING BELT WITH THE DIGITAL FORCE GAUGE

The HTD timing belts can be tensioned with a normal digital force gauge.

#### Step 1

To put the right tension on the HTD timing belts, the tensioners should be placed at their positions already. Push the tensioner towards the belt and in the meantime check the belt tension. It should be set according to the below numbers.

#### Step 2

When the tension is as it should be fasten both the M5x12 socket head screws. This way the tensioner should be fixed firmly and the tension should be kept on the belt.

The tension on the HTD timing belts should be:

Belt	Initial value	Running value (after 3 months)
325mm (between motor and first pulley)	20 N	20 N - 15,4 N
630mm (between the pulleys)	30 N	30 N - 23,1 N

See the below pictures where and how the measurement should be done. Flowsort allows a direction deviation of roughly 20° to the below indications.

For the 325mm short HTD timing belt between the motor and the first pulley the measurement should be done in this direction:

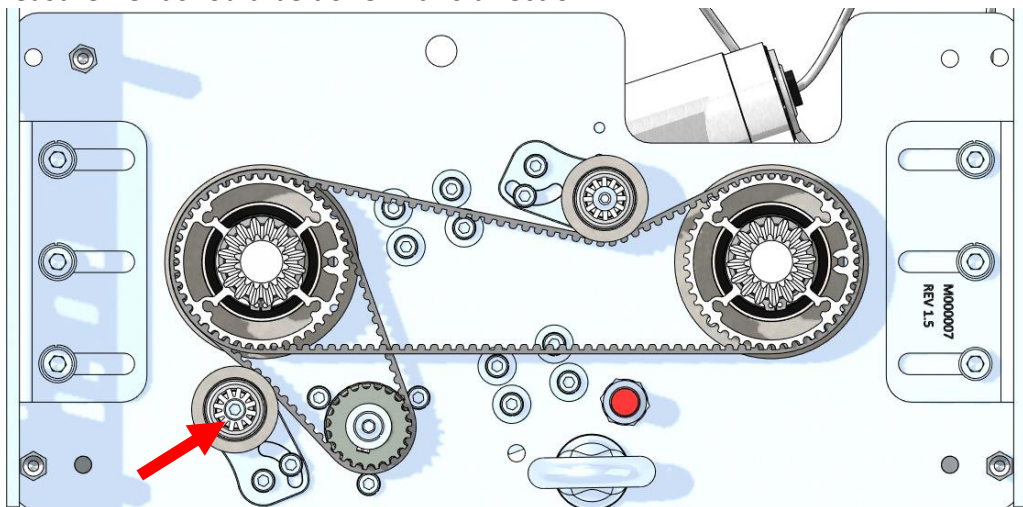

For the 630mm long HTD timing belt between the pulleys the measurement should be done in this direction:

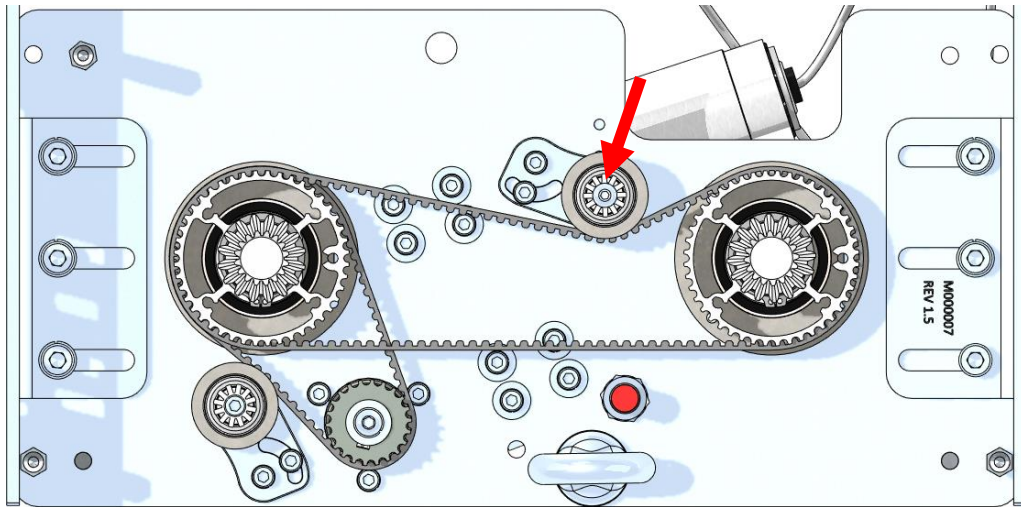

#### 6.7.4 TENSIONING THE POLY-V BELTS

The poly-V belts are used on the bottom side of the diverter for the transportation, the rotation of the blue wheels in the discs.

The 559mm belt is used between all the pulley drive assemblies on the bottom side. Every next pulley drive assemblies will get an additional 559mm belt with the specific tensioner. The tensioners will change every next time from high to low and vice versa.

### 6.7.5 TENSIONING THE POLY-V BELT WITH DIGITAL FORCE GAUGE

The poly-V belts can be tensioned with a normal digital force gauge

#### Step 1

To put the right tension on the poly-V belts, the tensioners should be placed at their positions already. Push the tensioner towards the belt and in the meantime check the belt tension. It should be set according to the below numbers.

#### Step 2

When the tension is as it should be fasten both the M5x12 socket head screws. In this way the tensioner should be fixed firmly and the tension on the belt should be kept on the belt.

The tension on the poly-V belt should be:

Belt	Initial value	Running value (after 3 months)
559mm	20 N	20 N - 15,4 N

See the below pictures where and how the measurement should be done. FlowSort allows a direction deviation of roughly 20° to the below indications.

For the 559mm long poly-V belt between the pulleys, the measurement should be done in this direction:

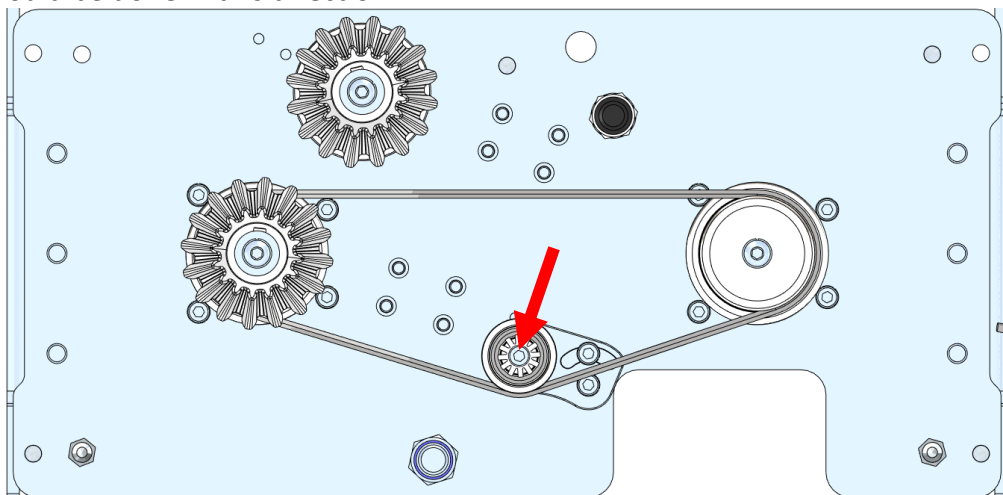

### 6.7.6 MAINTENANCE AND RE-TENSIONING

FlowSort recommends to check the belt tension:

- after **3 months** for sure
- every **8 to 10 weeks**

If this is done properly and on a regular base, we can see an improved life time of the belt and for the complete diverters.

**TROUBLESHOOTING**

**7.1 TROUBLESHOOTING**

In case of any issues with the diverters, see the below column to check the possible solution. Please contact Flowsort in any issue related topic.

<b>Issue</b>	<b>Cause</b>	<b>Avoidance</b>
Control card does not work	No power	Check power supply
	No signal inductive sensors	Clean sensor located under the wheel drive assembly with a different colour screw.
	Broken inductive sensors	Replace inductive sensor
	Zone controller is broken due damaging or used internal fuse	Replace control card
Control card shows failure	Motor is broken due to overheating	Check PGD drive and if necessary replace PGD drive
Wheel drive assembly is not running	Tooth wheel is damaged	Replace tooth wheel
	Tooth wheel of wheel drive assembly is damaged	Replace wheel drive assembly
	Poly-V belt is damaged	Replace belt
	Motor is damaged	Replace PGD drive
	Motor cable is damaged	Replace PGD drive
	Control card failure	Check issue "Control card does not work"
	Broken shaft	Replace pulley drive assembly
	HTD belt is damaged	Replace HTD belt
Wheel drive assembly is not rotating	Control card failure	Check issue "Control card does not work"
	Broken inductive sensor	Replace inductive sensor
	Motor is damaged	Replace PGD drive
	Motor cable is damaged	Replace PGD drive
	Bevel gear drive	Replace the bevel gear
Product flow goes wrong	Unit load is leaving the diverter in the wrong angle.	Check software and check inductive sensor
No tension on the belts	Broken/damaged tensioner	Replace belt tensioner
	Lose tensioner	Fasten the screws



**SPARE PARTS**

**8.7 SPARE PARTS**

See below the spare parts list for the SLD and DLD diverters.

Number	Article code	Description
1	S000003	Wheel drive assembly
2	S000029	Wheel drive assembly sensor
3	S000054	Pulley drive assembly poly-V
4	S000050	Tensioner poly-V high
5	S000051	Tensioner poly-V low
6	S000052	Tensioner flat high
7	S000053	Tensioner flat low
8	S000072	Pulley drive assembly poly-V and bevel gear
9	S000078	Bevel gear drive assembly
10	E000001	Motor; PGD024-SE2-11AAA
11	E000003	Controller; Conveylinx-Ai2
12	E000005	M12 Inductive sensor
13	E000034	Motor; PGD024-SE2-05AAA
14	I000005	Bevel Gear Ø10mm with keyway 3x3
15	I000013	Bevel Gear Ø16mm with keyway 5x5
16	V000005	Timing belt HTD 5M-325-9
17	V000029	Timing belt HTD 5M-630-9
18	V000055	Poly-V belt 559mm 4 ribs
19	V000082	Bevel gear aligner tool
20	S000001	Single wheel assembly
21	S000002	Double wheel assembly
22	V000004	Poly-V PJ belt 214mm 2ribs

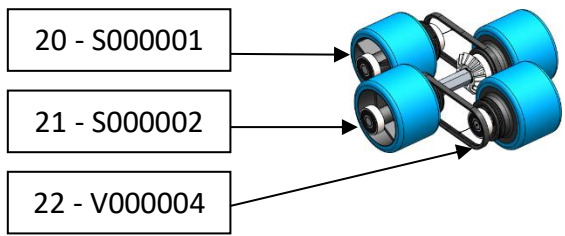
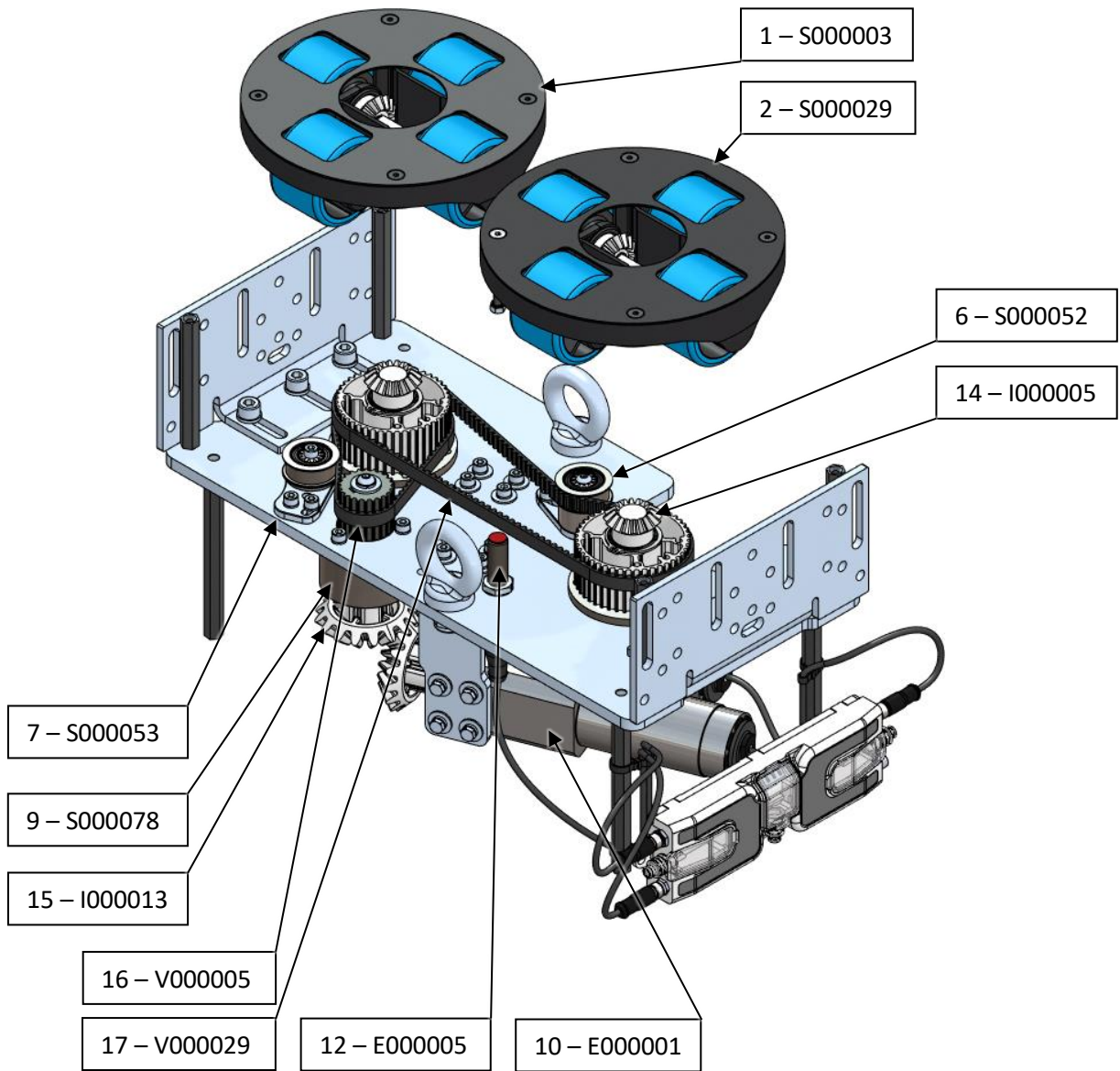

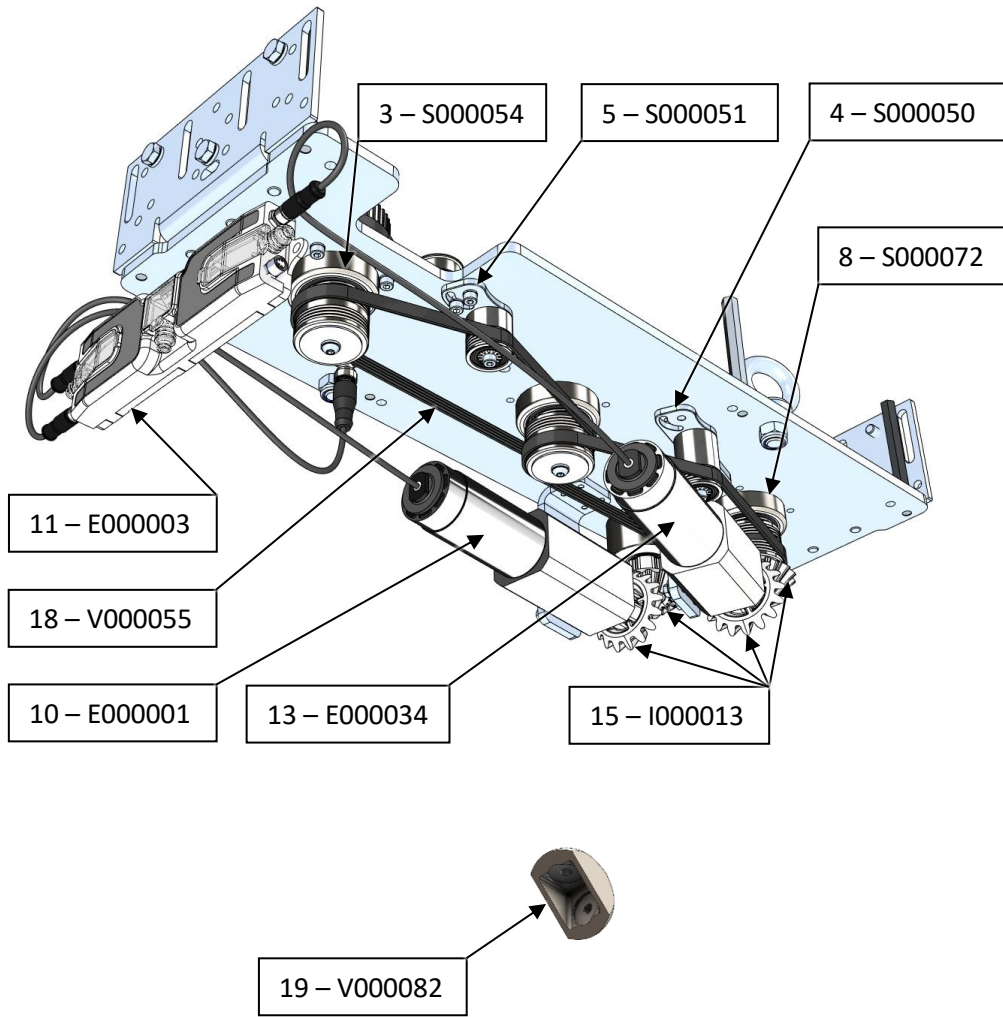

## DECLARATION OF INCORPORATION

### Declaration of Incorporation of partly completed machinery

*In accordance with the EC Machinery Directive 2006/42/EC, Appendix II 1 B*

**Manufacturer:**

**Flowsort Kft.**

Hungary

2040 Budaörs

Gyár u. 2.

**Declare under our own responsibility:**

- We are the producer of the following partly completed machinery to which this declaration relates:
  - Brand: **Flowsort**
  - Type: **Speed Flow Compact**
  - Serial number: All numbers
  - Function: Transporting unit loads
- This product is intended to be incorporated in machinery, or to be joined together with other products into a single machine in which the machine directive is applicable. This product is an incomplete machine according to the Machinery Directive 2006/42/EC and therefore does not fully meet the requirements of this directive.

The relevant technical documents are prepared in accordance with Annex VII B of this directive.
- The relevant technical documents (which include the risk assessment) will be kept by us and will be available to national authorities upon a reasoned request.
- It is forbidden to use this product before the machine in which the product is incorporated or of which it forms part is fully compliant with the Machinery Directive.
- The following requirements of annex 1 of Directive 2006/42/EC have not been met: 1.2, 1.2.4.3 and 1.31.
- The machine meets the requirements of the following other EC directives:
  - the EMC-directive 2014/30/EU (as last amended)

## DECLARATION OF CONFORMITY

Concerning the supply of Machinery (Safety) Regulations 2008 (appendix II 1 A)

**Manufacturer:**

**Flowsort Kft.**

Hungary

2040 Budaörs

Gyár u. 2.

**Declare entirely under our own responsibility:**

1. We are the manufacturer of the product:

Mark: **Flowsort**

Type: **Speed Flow Compact**

Function: conveying unit loads

Year of construction: from 2023

Serial no: All numbers

to which this declaration refers.

2. The machine has been designed and built conforming with the requirements of The supply of Machinery (Safety) Regulation 2008

3. The machine meets the requirements of the additional EC directives shown below:

- Electromagnetic Compatibility Regulations 2016

4. The machine has been designed and built in conforming with the European Standards:

BS-EN-ISO 12100-1:2010

Safety of machinery - General principles for design - Risk assessment and risk reduction

BS-EN-IEC 60204-1:2018

Safety of machinery - Electrical equipment of machines - Part 1: General requirements

**Note: This Declaration does not include all issues concerning the control system, such as: the wiring, programming and supply of control components for this is delivered by another party.**

**Date:**

09-04-2024

**Signed by:**

Till Zupancic - Flowsort BV



**Flowsort Kft.**

Gyár u. 2

2040 Budaörs

Hungary